

milwaukee *Cylinder*

Specials are Our Standard...

SERIES

LH

1 1/2" Thru
6" Bore
750 PSI to
1500 PSI



...Your Economy is in Our Quality

**Series "LH" Low Pressure
Hydraulic Cylinders
with Removable Retainers**

How to use this catalog...

Before selecting a cylinder, take a few moments to read through this catalog. Pay particular attention to the pages concerning design options and rod size selection.

A complete Index is shown below; A Quick Index is shown on the following page. The Complete Index is divided into sections according to subject with a brief description and the associated page number. The Quick Index illustrates the standard available mountings, with the number of the page containing dimensional data.

SUBJECT	DESCRIPTION	PAGE
GENERAL	QUICK INDEX	1LH
	STANDARD SPECIFICATIONS AND FEATURES	2LH
	PERFORMANCE TESTED DESIGN FEATURES	3LH
MOUNTING SPECIFICATIONS	PISTON ROD END STYLES	12LH
	TIE ROD MOUNTS	4LH
	FLANGE MOUNTS	6LH
	SIDE AND LUG MOUNTS	8LH
	PIN AND TRUNNION MOUNTS	10LH
	SOLID FLANGE MOUNTS	12LH
	KEY MOUNTS	20LH
	DOUBLE ROD END CYLINDERS	20LH
ACCESSORIES	CLEVIS	24LH
	BRACKETS	24LH
	PINS	24LH
	ROD EYES	24LH
DESIGN OPTIONS	SPECIAL CYLINDERS	13LH
	SPECIAL ROD ENDS	13LH
	SPECIAL ASSEMBLIES FROM STANDARD PARTS	13LH
	COMBINED MOUNTINGS	13LH
	CUSHION ADJUSTMENT LOCATIONS	15LH
	PORT LOCATIONS	15LH
	REMOVABLE TRUNNION PINS	15LH
	SINGLE ACTING CYLINDERS	15LH
	SINGLE ACTING SPRING CYLINDERS	15LH
	WATER SERVICE CYLINDERS	15LH
	PROXIMITY SWITCHES	15LH
	ADJUSTABLE STROKE CYLINDER	15LH
	PORTS	14LH
	STANDARD	14LH
	OVERSIZE	14LH
	STRAIGHT THREAD O-RING	14LH
	BLEED PORTS	14LH
	ROD BOOTS	14LH
METALLIC ROD WIPER	14LH	
ENGINEERING DATA	STOP TUBE	16LH
	ROD SIZE SELECTION	17LH
	HYDRAULIC PRESSURE AND FLOW DATA	17LH
	CYLINDER FORCE AND SPEED	15LH
INSTALLATION AND MAINTENANCE NOTES	STORAGE	18LH
	INSTALLATION	18LH
	CYLINDER TROUBLE SHOOTING	19LH
	CYLINDER MAINTENANCE	19LH
	SEAL KITS	21LH
	SEALS	21LH
ORDER INFORMATION	HOW TO ORDER	22LH
	CYLINDERS	22LH
	REPLACEMENT PARTS	22LH
	CYLINDER ORDER CODE – MODEL NUMBER	23LH

QUICK INDEX

MILWAUKEE Series LH low pressure hydraulic cylinders are built to perform on the toughest applications. Incorporating a variety of **MILWAUKEE** "Exclusive" advanced features, proven through the years, these cylinders will provide a long, maintenance-free service life. Advanced engineering combined with quality materials and expert workmanship contribute to the making of a rugged, top quality hydraulic cylinder.

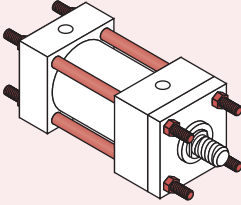
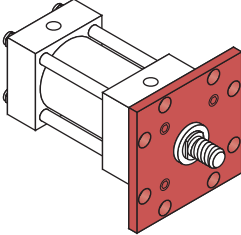
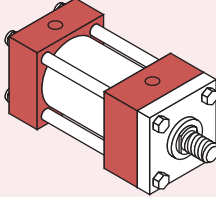
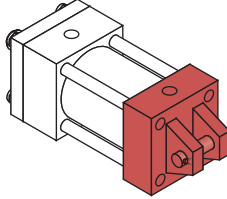
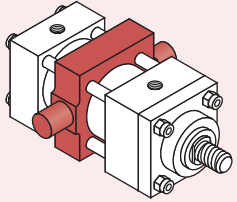
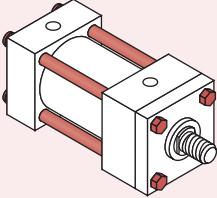
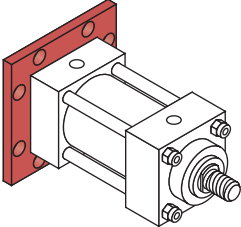
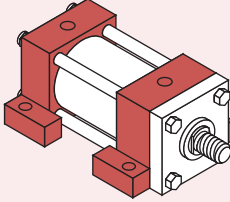
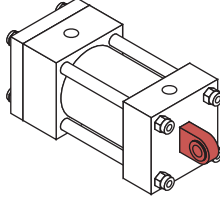
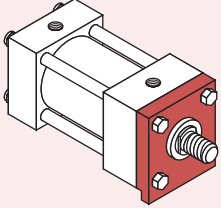
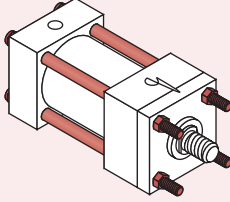
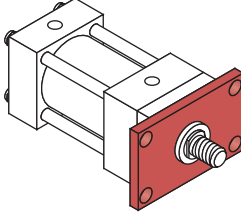
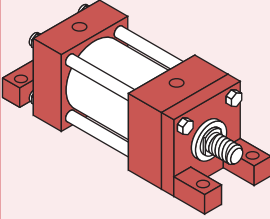
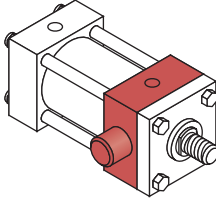
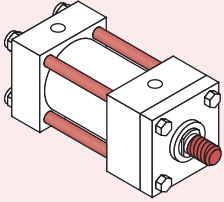
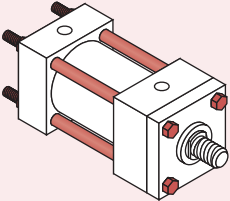
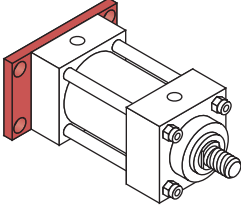
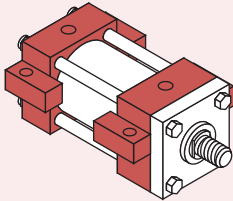
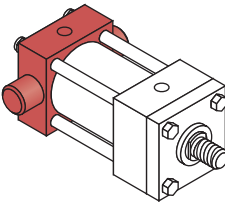
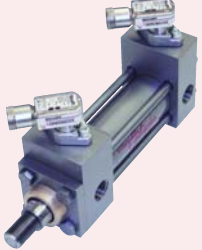
				
MODEL LH10 NFPA MX1 PAGE 4LH	MODEL LH21 NFPA MF5 PAGE 6LH	MODEL LH41 NFPA MS4 PAGE 8LH	MODEL LH61 NFPA MP1 PAGE 10LH	MODEL LH73 NFPA ME5 PAGE 10LH
				
MODEL LH11 NFPA MX PAGE 4LH	MODEL LH22 NFPA MF6 PAGE 6LH	MODEL LH42 NFPA MS2 PAGE 8LH	MODEL LH62 PAGE 10LH	MODEL— KEY MOUNT PAGE 20LH
				
MODEL LH12 NFPA MX3 PAGE 4LH	MODEL LH31 NFPA MF1 PAGE 6LH	MODEL LH43 NFPA MS7 PAGE 8LH	MODEL LH71 NFPA MT2 PAGE 10LH	DOUBLE ROD END NFPA MDX PAGE 20LH
				
MODEL LH13 NFPA MX2 PAGE 4LH	MODEL LH32 NFPA MF2 PAGE 6LH	MODEL LH51 NFPA MS3 PAGE 8LH	MODEL LH72 NFPA MT2 PAGE 10LH	PROXIMITY SWITCHES 13LH

Standard specifications and features

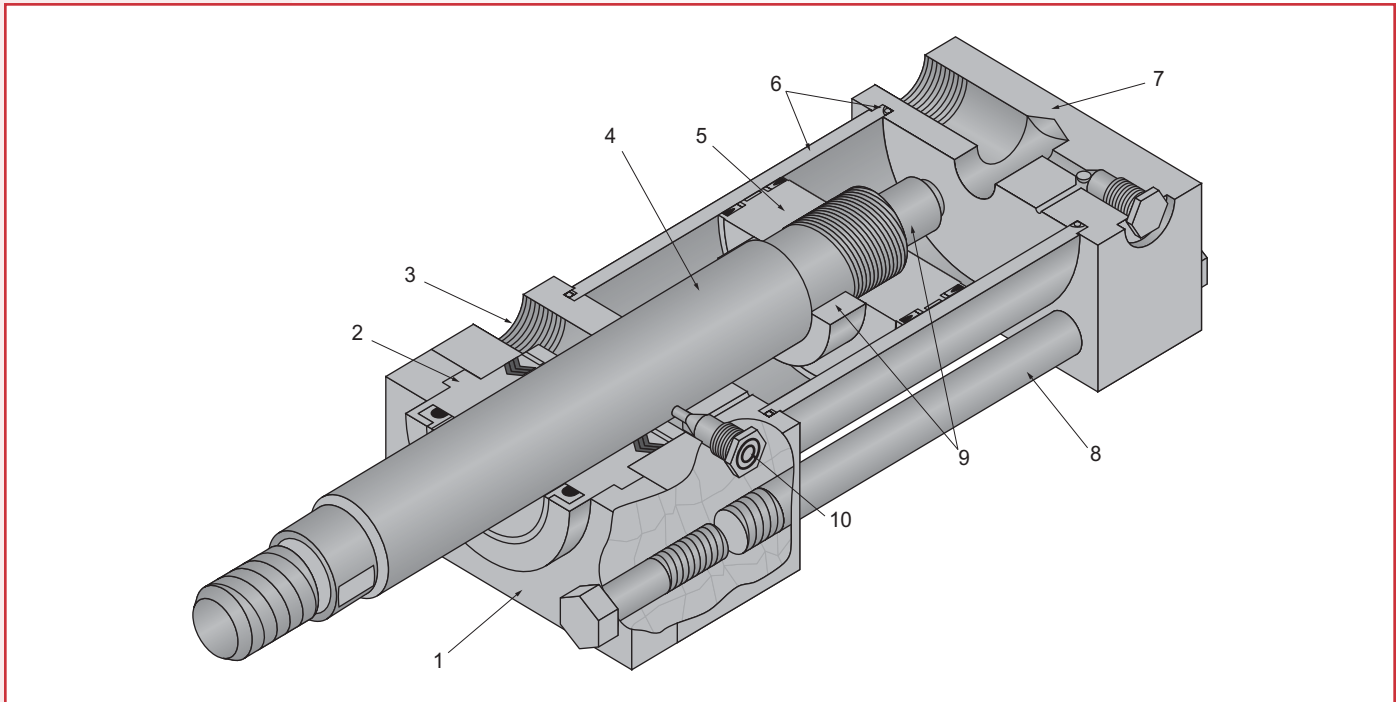

Standard Specifications

- **STANDARD CONSTRUCTION – SQUARE HEAD – TIE ROD DESIGN**
- **NOMINAL PRESSURE – 750 PSI TO 1500 PSI (REF. PG. 17LH, TABLE 8)**
- **STANDARD FLUID-HYDRAULIC OIL**
- **STANDARD TEMPERATURE – -20°F TO +250°F**
- **STANDARD BORE SIZES – 1 1/2" TO 6"**
- **STANDARD PISTON ROD DIAMETERS 5/8" THRU 4"**
- **STANDARD MOUNTING STYLES – 18 STANDARD STYLES PLUS CUSTOM DESIGNS TO SUIT YOUR NEEDS**
- **STROKES – AVAILABLE IN ANY STROKE LENGTH UP TO 240"**
- **CUSHIONS – AVAILABLE AT EITHER OR BOTH ENDS OF STROKE**
- **STANDARD 7 ROD END STYLES PLUS SPECIALS DESIGNED TO ORDER**
- **ROD END STYLE KK₂ IS STUDDED AS STANDARD FOR 5/8" AND 1" DIA. RODS. STUDDED ROD END STYLE IS AVAILABLE FOR ALL ROD SIZES**

Standard Features

- 1. Removable Retainer Plate**
The retainer plate and rod bushing are externally removable. On most models, total disassembly of the cylinder is not necessary. Four self-locking capscrews hold the retainer plate in place.
- 2. Rod Bushing and Seals**
A combination of spring loaded multiple lip vee rings with a supporting bronze bushing is standard in Milwaukee Series LH cylinders.
- 3. Ports**
Large NPTF cylinder ports are provided and can be rotated to any 90° position in relation to each other and the mounting. SAE ports available upon request.
- 4. Piston Rod**
The piston rod is of high strength steel, hardened and plated to resist scoring and corrosion to assure maximum seal life.
- 5. Piston**
The Series LH piston is precision machined from high strength aluminum alloy. It is pilot fitted and threaded to the piston rod.
- 6. Cylinder Barrel and Seals**
The barrel is of chrome plated steel tubing, honed to a fine finish to assure superior sealing, minimum friction and maximum seal life. It is step cut on the I.D. of both ends for O-ring seals.
- 7. End Caps**
End caps and mountings are of high quality steel, precision machined for accurate mounting.
- 8. Tie Rods**
The tie rods are constructed from a high quality medium carbon steel. The threads are accurately machined for rigid engagement of the nuts.
- 9. Cushions**
The cushions are machined to close tolerance to provide positive, smooth deceleration at the end of stroke.
- 10. Cushion Needle Adjustment and Ball Check**
The cushion needle adjustment valve and cushion-check ball retainer screw are specifically designed to provide full cushion adjustment and sealed with a Teflon ring to prevent leakage.

Performance tested design features

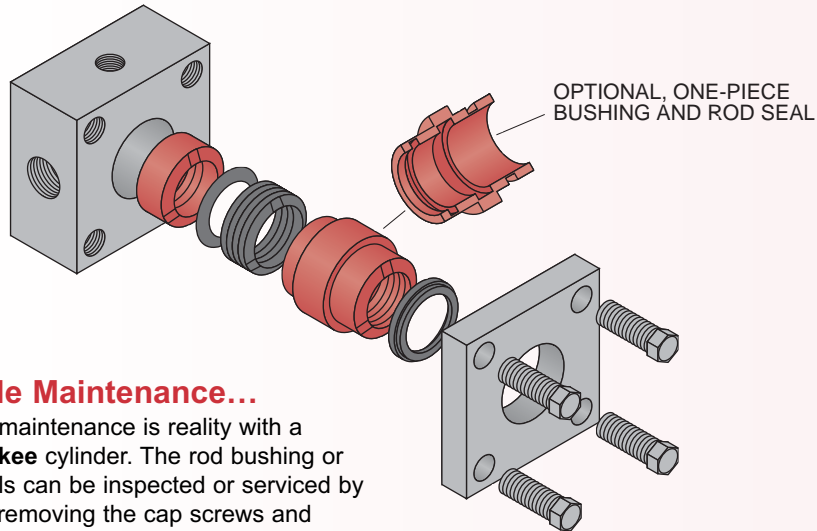

Simple Maintenance...

Simple maintenance is reality with a **Milwaukee** cylinder. The rod bushing or rod seals can be inspected or serviced by merely removing the cap screws and retainer plate on most models. Standard available shop tools can be used to remove the rod bushing and seals without disturbing the torque on the tie rods, assuring performance quality with maintenance ease.

Combination Rod Seal Design...

The **Milwaukee** Series LH cylinder combines spring loaded multiple lip vee rings with a supporting bronze bearing ring bushing and a double lip wiper as a secondary seal. This proven rod seal design combination is effective at both high and low pressures. It affords, in addition to maximum sealing, an extra long bearing support.

As an optional design, a one-piece rod bushing with a single lip block vee seal and a double lip wiper is available. Metallic rod scrapers may be supplied on request, in place of the double lip wiper with either rod bushing design.

The unique versatility of the **Milwaukee** Series LH design makes available a selection of seals to meet all types of service conditions.

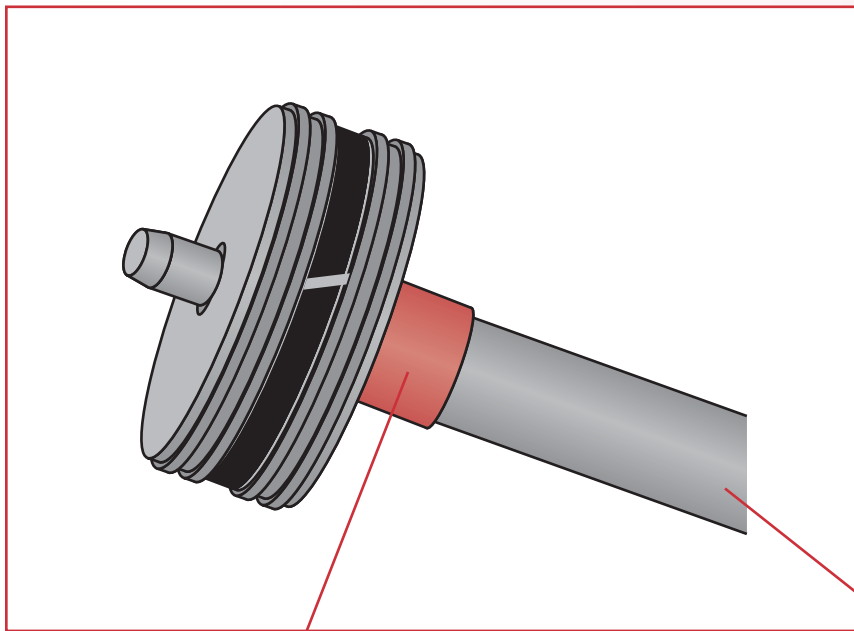

Piston and Seal Combination...

The **Milwaukee** Series LH cylinder combines a non-scoring wear ring with two block vee seals and a high strength aluminum alloy piston. This proven design combines low friction and smooth break away with the near zero leakage of the block vee seal.

CUSHIONS...

The cushion is of a high grade alloy, precision machined and specially tapered to provide smooth deceleration of the piston at the end of stroke. The rod end cushion bushing is floated on an O-ring to compensate for minor misalignments during normal operation. This is to assure that our customers receive the total quality of performance that is designed into a **Milwaukee** cylinder.

PISTON ROD...

The piston rod is hardened, plated high strength steel, machined and processed to resist scoring and corrosion, assuring maximum life. **Milwaukee** offers seven rod end styles as standard. The style #2 rod end with two wrench flats is furnished as standard, unless the customer specifies another style. Special rod ends and extra wrench flats are available at a slightly extra charge. They must be specified at the time of order, giving the dimensional requirements and the location of additional wrench flats.

TIE-ROD MOUNT

The flange and tie-rod mounts are basically the same, except that the cylinder tie-rods are extended and used to mount the cylinder. To prevent misalignment, sagging or possible binding of the cylinder, when long strokes are required, the free end should be supported.

The blind end is in a thrust load application. When using tie-rods extended on the rod end, the best application is a tension load. Tie-rod mounts are suited for many applications, but it should be noted that they are not as rigid as the flange type of mounting.

The best use of tie-rods when extending on the

FOR PACKAGE AND MOUNTING DIMENSION SEE TABLES 1 AND 2

TIE-RODS EXTENDED BOTH ENDS

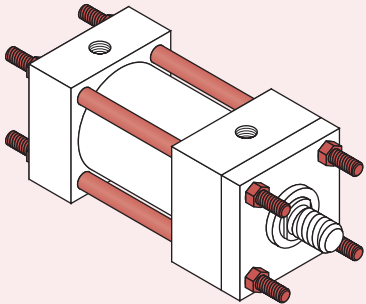

MODEL LH10
NFFA STYLE MX1

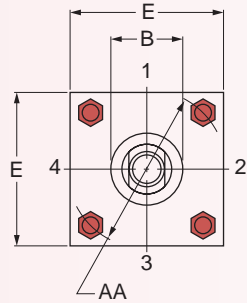
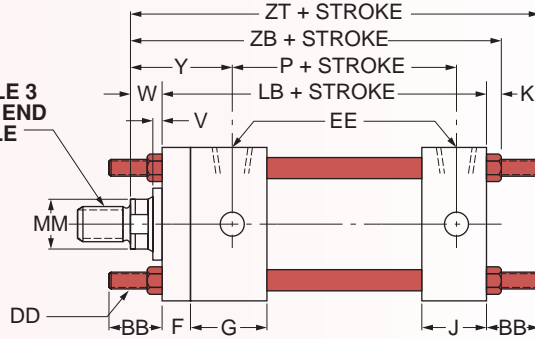
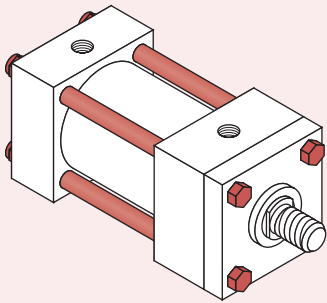

TABLE 3
ROD END
STYLE



NO TIE-ROD EXTENSION



MODEL LH11
NFFA STYLE MX

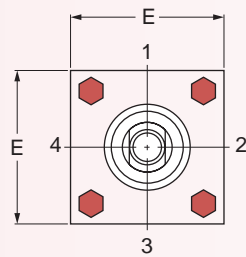
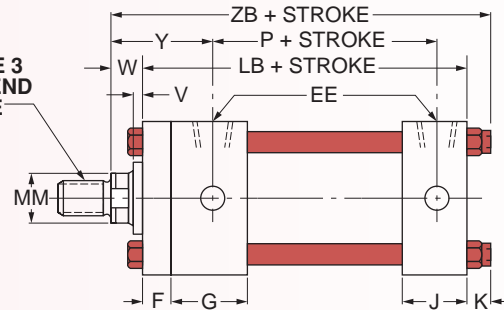
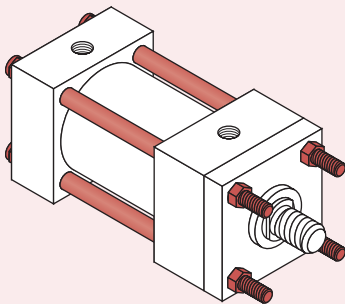

TABLE 3
ROD END
STYLE



TIE-RODS EXTENDED ROD END



MODEL LH12
NFFA STYLE MX3

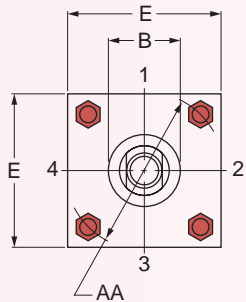
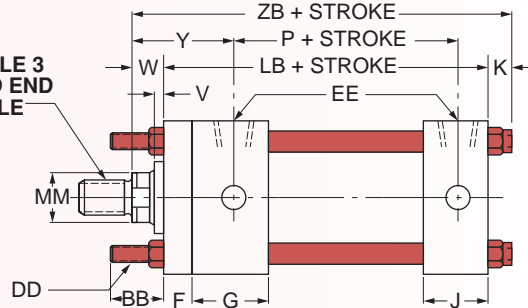
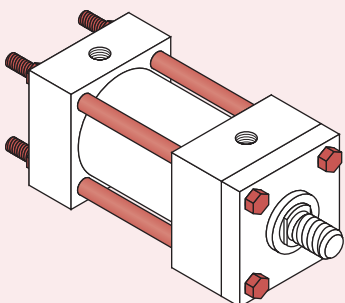

TABLE 3
ROD END
STYLE



TIE RODS EXTENDED BLIND END



MODEL LH13
NFFA STYLE MX2
4LH

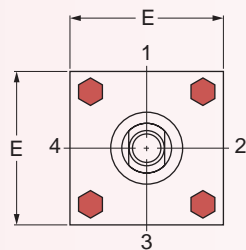
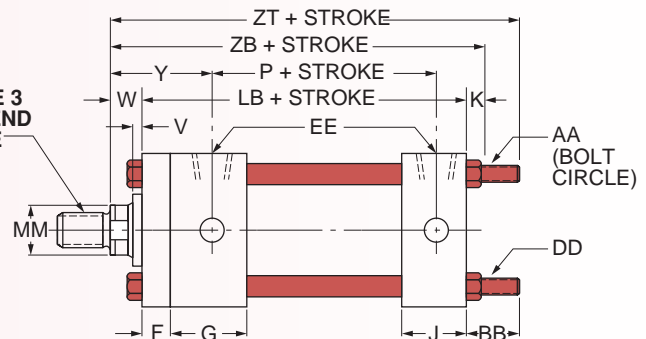

TABLE 3
ROD END
STYLE



Dimensional Data

TABLE 1 The dimensions given on this table are affected by the piston rod diameter and the stroke.

BORE DIA.	ROD MM	CYLINDER CODE #	B	LB	P	V	W	Y	ZB	ZT
1½	5/8	LH051	1 1/8	4	2 1/4	1/4	5/8	1 15/16	5	5 5/8
	•1	LH052	1 1/2			1/2	1	2 5/16	5 3/8	6
2	5/8	LH510	1 1/8	4	2 1/4	1/4	5/8	1 15/16	5 1/16	5 3/4
	1	LH511	1 1/2			1/2	1	2 5/16	5 7/16	6 1/8
2½	•1 3/8	LH512	2	4 1/8	2 3/8	5/8	1 1/4	2 9/16	5 11/16	6 3/8
	5/8	LH520	1 1/8			1/4	5/8	1 15/16	5 3/16	5 7/8
	1	LH521	1 1/2			1/2	1	2 5/16	5 9/16	6 1/4
	1 3/8	LH522	2			5/8	1 1/4	2 9/16	5 13/16	6 1/2
3¼	•1 3/4	LH523	2 3/8	4 7/8	2 5/8	3/4	1 1/2	2 13/16	6 1/16	6 3/4
	1	LH530	1 1/2			1/4	3/4	2 7/16	6 1/8	7
	1 3/8	LH531	2			3/8	1	2 11/16	6 3/8	7 1/4
	1 3/4	LH532	2 3/8			1/2	1 1/4	2 15/16	6 5/8	7 1/2
4	2	LH533	2 5/8	4 7/8	2 5/8	1/2	1 3/8	3 1/16	6 3/4	7 5/8
	1	LH540	1 1/2			1/4	3/4	2 7/16	6 1/8	7
	1 3/8	LH541	2			3/8	1	2 11/16	6 3/8	7 1/4
	1 3/4	LH542	2 3/8			1/2	1 1/4	2 15/16	6 5/8	7 1/2
	2	LH543	2 5/8			1/2	1 3/8	3 1/16	6 3/4	7 5/8
5	2 1/2	LH544	3 1/8	5 1/8	2 7/8	5/8	1 5/8	3 5/16	7	7 7/8
	1	LH550	1 1/2			1/4	3/4	2 7/16	6 7/16	7 11/16
	1 3/8	LH551	2			3/8	1	2 11/16	6 11/16	7 15/16
	1 3/4	LH552	2 3/8			1/2	1 1/4	2 15/16	6 15/16	8 3/16
	2	LH553	2 5/8			1/2	1 3/8	3 1/16	7 1/16	8 5/16
	6	3	LH554			3 1/8	5 3/4	3 1/8	5/8	1 5/8
3 1/2		LH555	3 3/4	5/8	1 5/8	3 5/16			7 5/16	8 9/16
1 3/8		LH560	2	1/4	7/8	2 13/16			7 3/16	8 7/16
1 3/4		LH561	2 3/8	3/8	1 1/8	3 1/16			7 7/16	8 11/16
6	2	LH562	2 5/8	5 3/4	3 1/8	3/8	1 1/4	3 3/16	7 9/16	8 13/16
	2 1/2	LH563	3 1/8			1/2	1 1/2	3 7/16	7 13/16	9 1/16
	3	LH564	3 3/4			1/2	1 1/2	3 7/16	7 13/16	9 1/16
	3 1/2	LH565	4 1/4			1/2	1 1/2	3 7/16	7 13/16	9 1/16
4	LH566	4 3/4	1/2	1 1/2	3 7/16	7 13/16	9 1/16			

HOW TO ORDER

For ordering information refer to Page 23LH.

NOTES:

For double rod end cylinders, the cylinder code number is to be written with the letter D. (Refer to page 20LH.)

- Available with fixed-nonadjustable cushions on rod end and standard adjustable cushions on the blind end only.

CUSHIONS:

The longest cushion is provided that can be accommodated by the rod and blind end caps in any given bore size. Longer cushions are available; for further information, consult the factory.

PORTS:

Series LH Cylinders are supplied with NPTF tapered pipe threads as standard. The largest size port is provided that can be accommodated by the rod and blind end caps in any given bore size. For further information on different types of ports or oversized ports, refer to page 14LH.

SEE TABLE 3 PAGE 12LH FOR ROD END STYLES AND DIMENSIONS

TABLE 2 The dimensions are constant regardless of rod diameter or stroke.

BORE	AA	BB	DD	E	EE	F	G	J	K
1½	2.02	1	1/4-28	2	3/8	3/8	1 1/2	1	3/8
2	2.60	1 1/8	5/16-24	2 1/2	3/8	3/8	1 1/2	1	7/16
2½	3.10	1 1/8	5/16-24	3	3/8	3/8	1 1/2	1	7/16
3¼	3.90	1 3/8	3/8-24	3 3/4	1/2	5/8	1 3/4	1 1/4	1/2
4	4.70	1 3/8	3/8-24	4 1/2	3/4	5/8	1 3/4	1 1/4	1/2
5	5.80	1 13/16	1/2-20	5 1/2	1/2	5/8	1 3/4	1 1/4	9/16
6	6.90	1 13/16	1/2-20	6 1/2	3/4	3/4	2	1 1/2	9/16

FLANGE MOUNT

The flange mount is one of the strongest, most rigid methods of mounting. With this type of mount there is little allowance for misalignment, though when long strokes are required, the free end opposite the mounting should be supported to prevent sagging and possible binding of the cylinder. The best use of a blind end flange is in

a thrust load application (rod in compression). Rod end flange mounts are best used in tension applications. When a less rigid mount can be used and the cylinder can be attached to a panel or bulkhead, an extended tie-rod mounting could be considered.

FOR PACKAGE AND MOUNTING DIMENSIONS SEE TABLES 1 AND 2

ROD SQUARE FLANGE MOUNTING

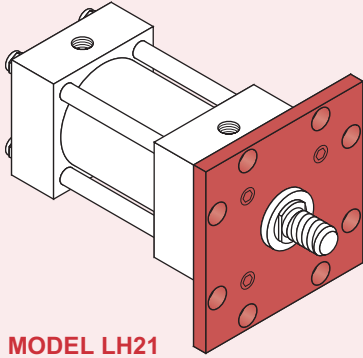

MODEL LH21
NFFA STYLE MF5

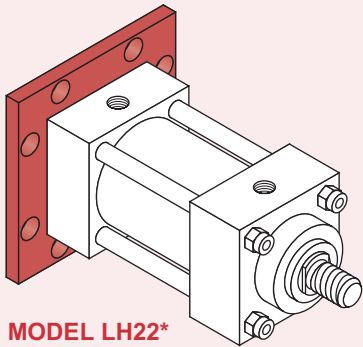
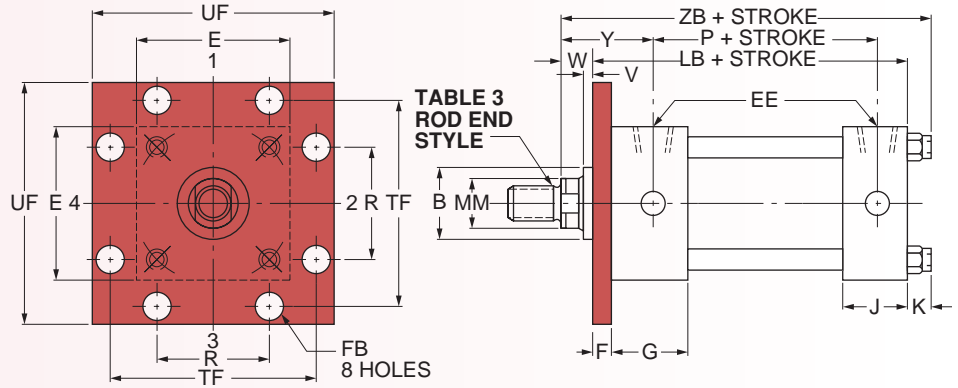

MODEL LH22*
NFFA STYLE MF6

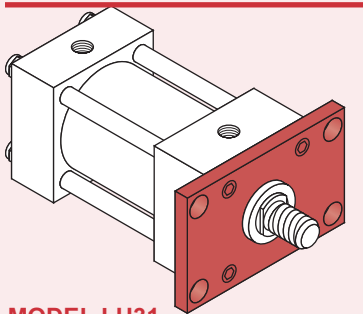
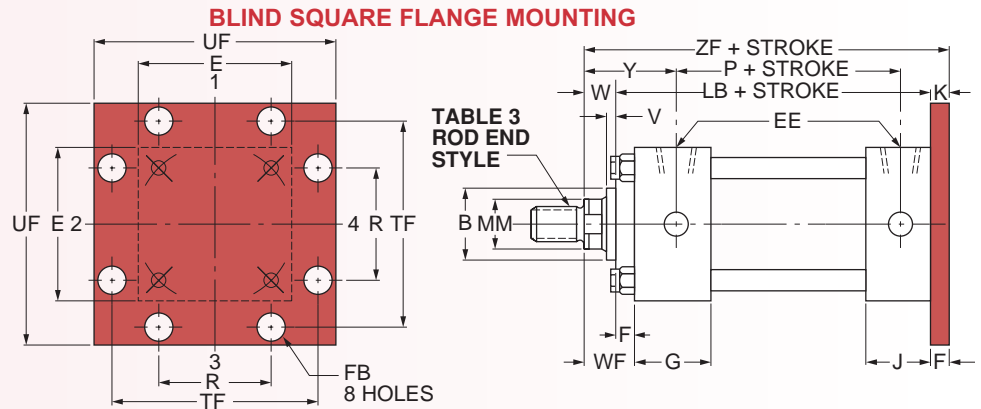

MODEL LH31
NFFA STYLE MF1

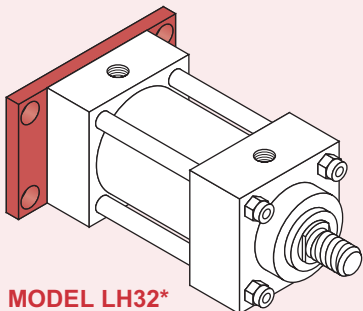
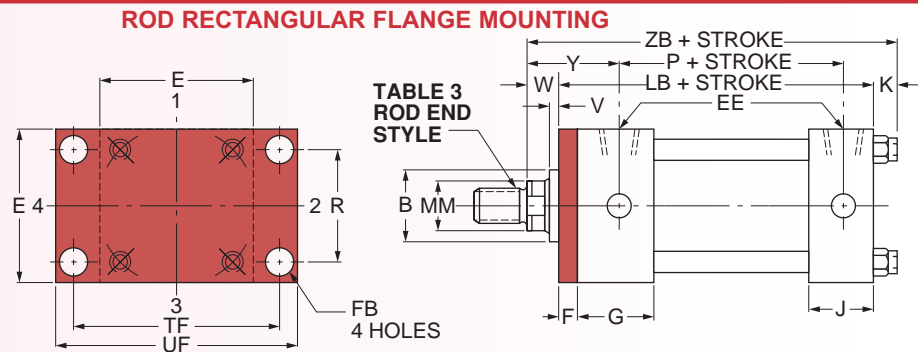

MODEL LH32*
NFFA STYLE MF2
6LH

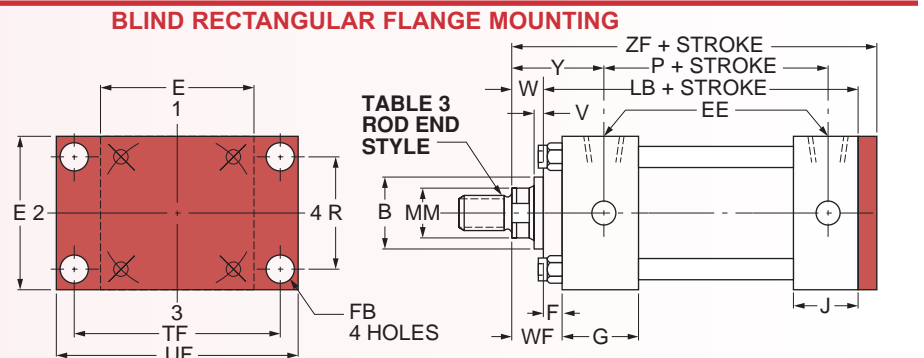

Dimensional Data

TABLE 1 The dimensions given on this table are affected by the piston rod diameter and the stroke.

BORE DIA.	ROD MM	CYLINDER CODE #	B	LB	P	V	W	Y	ZB	ZF
1 1/2	5/8	LH051	1 1/8	4	2 1/4	1/4	5/8	1 15/16	5	5
	•1*	LH052	1 1/2			1/2	1	2 5/16	5 3/8	5 3/8
2	5/8	LH510	1 1/8	4	2 1/4	1/4	5/8	1 15/16	5 1/16	5
	1	LH511	1 1/2			1/2	1	2 5/16	5 7/16	5 3/8
2 1/2	•1 3/8*	LH512	2	4 1/8	2 3/8	5/8	1 1/4	2 9/16	5 11/16	5 5/8
	5/8	LH520	1 1/8			1/4	5/8	1 15/16	5 3/16	5 1/8
	1	LH521	1 1/2			1/2	1	2 5/16	5 9/16	5 1/2
	1 3/8	LH522	2			5/8	1 1/4	2 9/16	5 13/16	5 3/4
3 1/4	•1 3/4*	LH523	2 3/8	4 7/8	2 5/8	3/4	1 1/2	2 13/16	6 1/16	6
	1	LH530	1 1/2			1/4	3/4	2 7/16	6 1/8	6 1/4
	1 3/8	LH531	2			3/8	1	2 11/16	6 3/8	6 1/2
	1 3/4	LH532	2 3/8			1/2	1 1/4	2 15/16	6 5/8	6 3/4
4	2*	LH533	2 5/8	4 7/8	2 5/8	1/2	1 3/8	3 1/16	6 3/4	6 7/8
	1	LH540	1 1/2			1/4	3/4	2 7/16	6 1/8	6 1/4
	1 3/8	LH541	2			3/8	1	2 11/16	6 3/8	6 1/2
	1 3/4	LH542	2 3/8			1/2	1 1/4	2 15/16	6 5/8	6 3/4
	2	LH543	2 5/8			1/2	1 3/8	3 1/16	6 3/4	6 7/8
5	2 1/2*	LH544	3 1/8	5 1/8	2 7/8	5/8	1 5/8	3 5/16	7	7 1/8
	1	LH550	1 1/2			1/4	3/4	2 7/16	6 7/16	6 1/2
	1 3/8	LH551	2			3/8	1	2 11/16	6 11/16	6 3/4
	1 3/4	LH552	2 3/8			1/2	1 1/4	2 15/16	6 15/16	7
	2	LH553	2 5/8			1/2	1 3/8	3 1/16	7 1/16	7 1/8
	2 1/2	LH554	3 1/8			5/8	1 5/8	3 5/16	7 5/16	7 3/8
6	3	LH555	3 3/4	5 3/4	3 1/8	5/8	1 5/8	3 5/16	7 5/16	7 3/8
	3 1/2*	LH556	4 1/4			5/8	1 5/8	3 5/16	7 5/16	7 3/8
	1 3/8	LH560	2			1/4	7/8	2 13/16	7 3/16	7 3/8
	1 3/4	LH561	2 3/8			3/8	1 1/8	3 1/16	7 7/16	7 5/8
	2	LH562	2 5/8			3/8	1 1/4	3 3/16	7 9/16	7 3/4
	2 1/2	LH563	3 1/8			1/2	1 1/2	3 7/16	7 13/16	8
	3	LH564	3 3/4			1/2	1 1/2	3 7/16	7 13/16	8
3 1/2	LH565	4 1/4	1/2	1 1/2	3 7/16	7 13/16	8			
4	LH566	4 3/4	1/2	1 1/2	3 7/16	7 13/16	8			

HOW TO ORDER

For ordering information refer to Page 23LH.

NOTES:

For double rod end cylinders, the cylinder code number is to be written with the letter D. (Refer to page 20LH.)

• Available with fixed-nonadjustable cushions on rod end and standard adjustable cushions on the blind end only.

* Removable retainer not available for these bore and rod combinations in the LH22 and LH32 mounting styles.

PORTS:

Series LH Cylinders are supplied with NPTF tapered pipe threads as standard. The largest size port is provided that can be accommodated by the rod and blind end caps in any given bore size. For further information on different types of ports or over-sized ports, refer to page 14LH.

CUSHIONS:

The longest cushion is provided that can be accommodated by the rod and blind end caps in any given bore size. Longer cushions are available; for further information, consult the factory.

SEE TABLE 3 PAGE 12LH FOR ROD END STYLES AND DIMENSIONS

TABLE 2 The dimensions are constant regardless of rod diameter or stroke.

BORE DIA.	E	EE	F	FB	G	J	K	R	TF	UF
1 1/2	2	3/8	3/8	5/16	1 1/2	1	3/8	1.43	2 3/4	3 3/8
2	2 1/2	3/8	3/8	3/8	1 1/2	1	7/16	1.84	3 3/8	4 1/8
2 1/2	3	3/8	3/8	3/8	1 1/2	1	7/16	2.19	3 7/8	4 5/8
3 1/4	3 3/4	1/2	5/8	7/16	1 3/4	1 1/4	1/2	2.76	4 11/16	5 1/2
4	4 1/2	1/2	5/8	7/16	1 3/4	1 1/4	1/2	3.32	5 7/16	6 1/4
5	5 1/2	1/2	5/8	9/16	1 3/4	1 1/4	9/16	4.10	6 5/8	7 5/8
6	6 1/2	3/4	3/4	9/16	2	1 1/2	9/16	4.88	7 5/8	8 5/8

SIDE AND LUG MOUNTS

The side or lug mounted cylinder provides a fairly rigid mount. These types of cylinders can tolerate a slight amount of misalignment when the cylinder is at full stroke, but as the piston moves toward the blind end, the tolerance for

misalignment decreases. It is important to note that if the cylinder is used properly (without misalignment), the mounting bolts are either in simple shear or tension without any compound stresses.

FOR PACKAGE AND MOUNTING DIMENSIONS SEE TABLES 1 AND 2

TAPPED HOLES IN CAPS FLUSH MOUNTING

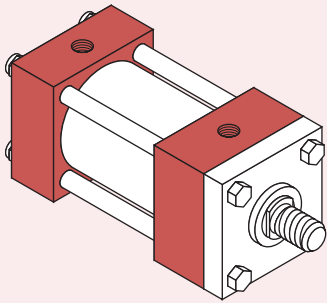

**MODEL LH41
NFPA STYLE MS4**

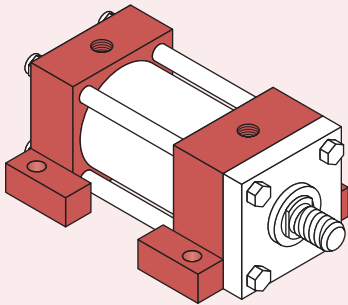
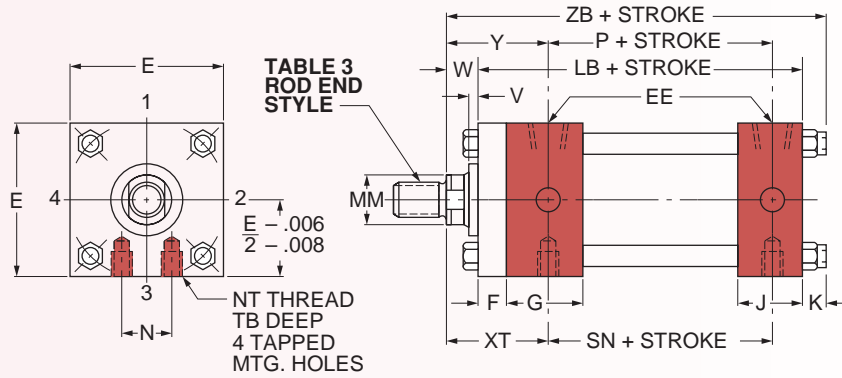

**MODEL LH42
NFPA STYLE MS2**

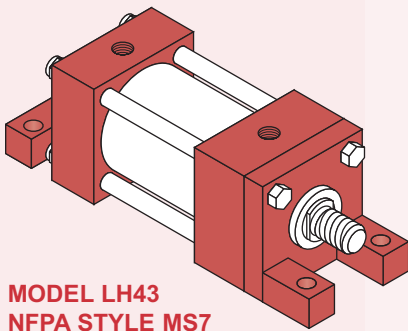
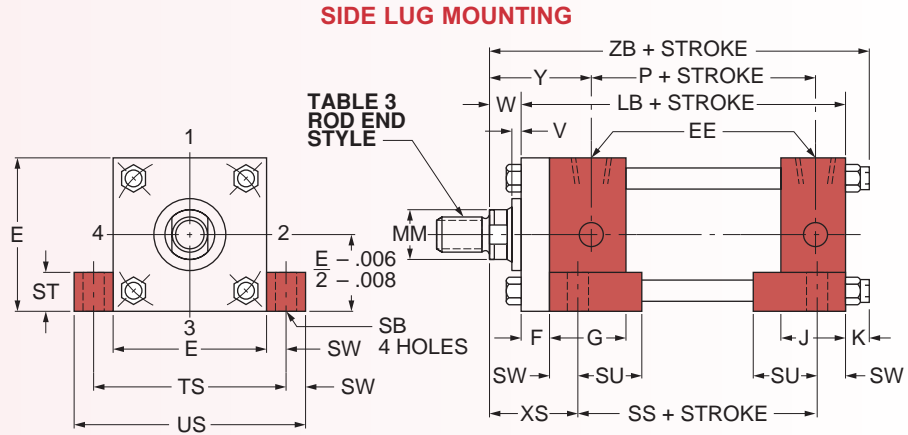

**MODEL LH43
NFPA STYLE MS7**

NOT AVAILABLE WITH REMOVABLE RETAINERS

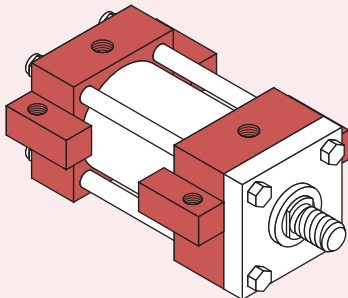
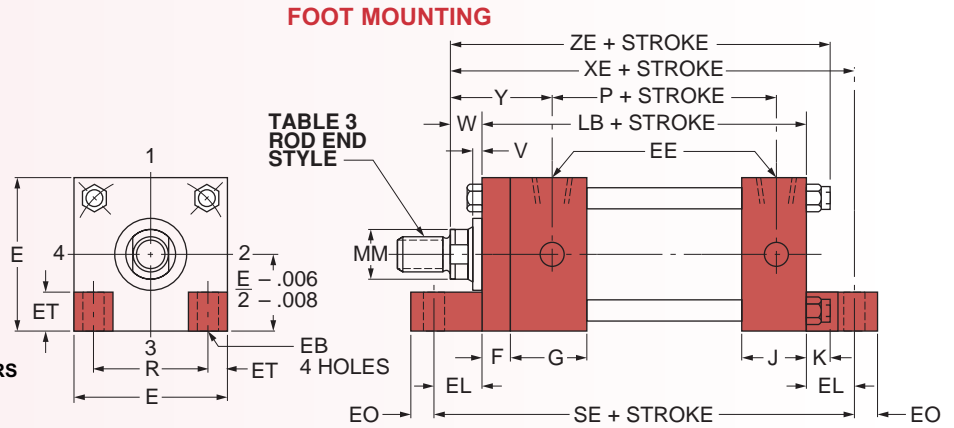

**MODEL LH51
NFPA STYLE MS3**

8LH

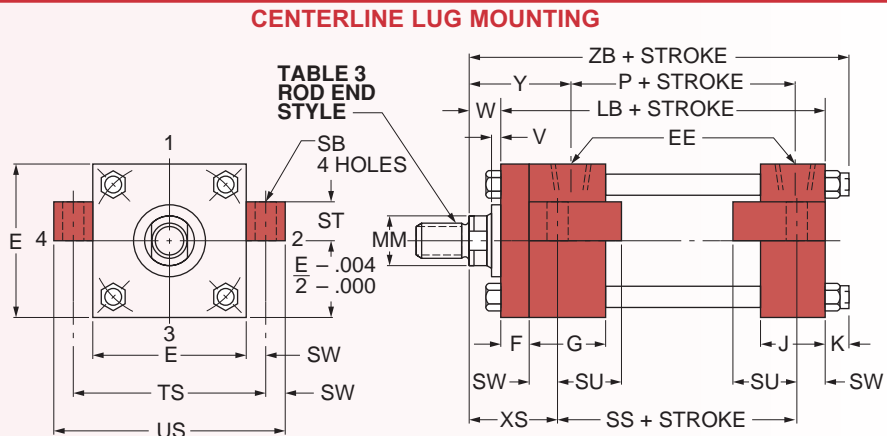

Dimensional Data

TABLE 1 The dimensions given on this table are affected by the piston rod diameter and the stroke.

BORE DIA.	ROD MM	CYLINDER CODE#	LB	P	SE▲	SN	SS■	V	W	XE	XS	XT	Y	ZB	ZE
1 1/2	5/8	LH0151	4	2 1/4	5 1/2	2 1/4	2 7/8	1/4	5/8	5 3/8	1 3/8	1 15/16	1 15/16	5	5 5/8
	•1*	LH0152						1/2	1	5 3/4	1 3/4	2 5/16	2 5/16	5 3/8	6
2	5/8	LH0510	4	2 1/4	5 7/8	2 1/4	2 7/8	1/4	5/8	5 9/16	1 3/8	1 15/16	1 15/16	5 1/16	5 7/8
	†1*	LH0511						1/2	1	5 15/16	1 3/4	2 5/16	2 5/16	5 7/16	6 1/4
	•1 3/8*	LH0512						5/8	1 1/4	6 3/16	2	2 9/16	2 9/16	5 11/16	6 1/2
2 1/2	5/8	LH0520	4 1/8	2 3/8	6 1/4	2 3/8	3	1/4	5/8	5 13/16	1 3/8	1 15/16	1 15/16	5 3/16	6 1/8
	1	LH0521						1/2	1	6 3/16	1 3/4	2 5/16	2 5/16	5 9/16	6 1/2
	†1 3/8*	LH0522						5/8	1 1/4	6 7/16	2	2 9/16	2 9/16	5 13/16	6 3/4
	•1 3/4*	LH0523						3/4	1 1/2	6 11/16	2 1/4	2 13/16	2 13/16	6 1/16	7
3 1/4	1	LH0530	4 7/8	2 5/8	6 5/8	2 5/8	3 1/4	1/4	3/4	6 1/2	1 7/8	2 7/16	2 7/16	6 1/8	6 7/8
	1 3/8	LH0531						3/8	1	6 3/4	2 1/8	2 11/16	2 11/16	6 3/8	7 1/8
	1 3/4*	LH0532						1/2	1 1/4	7	2 3/8	2 15/16	2 15/16	6 5/8	7 3/8
	2*	LH0533						1/2	1 3/8	7 1/8	2 1/2	3 1/16	3 1/16	6 3/4	7 1/2
4	1	LH0540	4 7/8	2 5/8	6 7/8	2 5/8	3 1/4	1/4	3/4	6 5/8	1 7/8	2 7/16	2 7/16	6 1/8	7
	1 3/8	LH0541						3/8	1	6 7/8	2 1/8	2 11/16	2 11/16	6 3/8	7 1/4
	1 3/4	LH0542						1/2	1 1/4	7 1/8	2 3/8	2 15/16	2 15/16	6 5/8	7 1/2
	2	LH0543						1/2	1 3/8	7 1/4	2 1/2	3 1/16	3 1/16	6 3/4	7 5/8
	2 1/2*	LH0544						5/8	1 5/8	7 1/2	2 3/4	3 5/16	3 5/16	7	7 7/8
5	1	LH0550	5 1/8	2 7/8	7 1/4	2 7/8	3 1/8	1/4	3/4	6 15/16	2 1/16	2 7/16	2 7/16	6 7/16	7 7/16
	1 3/8	LH0551						3/8	1	7 3/16	2 5/16	2 11/16	2 11/16	6 11/16	7 11/16
	1 3/4	LH0552						1/2	1 1/4	7 7/16	2 9/16	2 15/16	2 15/16	6 15/16	7 15/16
	2	LH0553						1/2	1 3/8	7 9/16	2 11/16	3 1/16	3 1/16	7 1/16	8 1/16
	2 1/2	LH0554						5/8	1 5/8	7 13/16	2 15/16	3 5/16	3 5/16	7 5/16	8 5/16
	3	LH0555						5/8	1 5/8	7 13/16	2 15/16	3 5/16	3 5/16	7 5/16	8 5/16
3 1/2*	LH0556	5/8	1 5/8	7 13/16	2 15/16	3 5/16	3 5/16	7 5/16	8 5/16						
6	1 3/8	LH0560	5 3/4	3 1/8	7 3/4	3 1/8	3 5/8	1/4	7/8	7 5/8	2 5/16	2 13/16	2 13/16	7 13/16	8 1/8
	1 3/4	LH0561						3/8	1 1/8	7 7/8	2 9/16	3 1/16	3 1/16	7 7/16	8 3/8
	2	LH0562						3/8	1 1/4	8	2 11/16	3 3/16	3 3/16	7 9/16	8 1/2
	2 1/2	LH0563						1/2	1 1/2	8 1/4	2 15/16	3 7/16	3 7/16	7 13/16	8 3/4
	3	LH0564						1/2	1 1/2	8 1/4	2 15/16	3 7/16	3 7/16	7 13/16	8 3/4
	3 1/2	LH0565						1/2	1 1/2	8 1/4	2 15/16	3 7/16	3 7/16	7 13/16	8 3/4
4*	LH0566	1/2	1 1/2	8 1/4	2 15/16	3 7/16	3 7/16	7 13/16	8 3/4						

HOW TO ORDER

For ordering information refer to Page 23LH.

NOTES:

- * Model LH41 is not available in these sizes.
- † The standard rod eye or rod clevis will interfere with foot lugs on Model LH43. When these rod end accessories are required, use additional rod extension.
- ▲ For double rod end cylinders from 1 1/2" thru 6" bore, add 1/2 + F to this dimension.
- For double rod end cylinders from 1 1/2" thru 6" bore, add 1/2 to this dimension.
- Available with fixed-nonadjustable cushions on rod end and standard adjustable cushions on the blind end only
- # For double rod end cylinders, the cylinder code number is to be written with the letter D. (Refer to page 20LH.)

PORTS:

Series LH Cylinders are supplied with NPTF tapered pipe threads as standard. The largest size port is provided that can be accommodated by the rod and blind end caps in any given bore size. For further information on different types of ports or over-sized ports, refer to page 14LH.

CUSHIONS:

The longest cushion is provided that can be accommodated by the rod and blind end caps in any given bore size. Longer cushions are available; for further information, consult the factory.

SEE TABLE 3 PAGE 12LH FOR ROD END STYLES AND DIMENSIONS

TABLE 2 The dimensions are constant regardless of rod diameter or stroke.

BORE DIA.	E	EB	EE	EL	EO	ET	F	G	J	K	NT	R	SB	ST	SU	SW	TB	TN	TS	US
1 1/2	2	5/16	3/8	3/4	1/4	1/2	3/8	1 1/2	1	3/8	1/4-20	1.43	7/16	1/2	15/16	3/8	3/8	5/8	2 3/4	3 1/2
2	2 1/2	3/8	3/8	15/16	5/16	19/32	3/8	1 1/2	1	7/16	5/16-18	1.84	7/16	1/2	15/16	3/8	9/16	7/8	3 1/4	4
2 1/2	3	3/8	3/8	1 1/16	5/16	3/4	3/8	1 1/2	1	7/16	3/8-16	2.19	7/16	1/2	15/16	3/8	5/8	1 1/4	3 3/4	4 1/2
3 1/4	3 3/4	7/16	1/2	7/8	3/8	29/32	5/8	1 3/4	1 1/4	1/2	1/2-13	2.76	9/16	3/4	1 1/4	1/2	3/4	1 1/2	4 3/4	5 3/4
4	4 1/2	7/16	1/2	1	3/8	1 1/8	5/8	1 3/4	1 1/4	1/2	1/2-13	3.32	9/16	3/4	1 1/4	1/2	1	2 1/16	5 1/2	6 1/2
5	5 1/2	9/16	1/2	1 1/16	1/2	1 11/32	5/8	1 3/4	1 1/4	9/16	5/8-11	4.10	13/16	1	1 9/16	1 1/16	1	2 11/16	6 7/8	8 1/4
6	6 1/2	9/16	3/4	1	1/2	1 9/16	3/4	2	1 1/2	9/16	3/4-10	4.88	13/16	1	1 9/16	1 1/16	1 1/8	3 1/4	7 7/8	9 1/4

PIN AND TRUNNION MOUNTS

All pin and trunnion cylinders need a provision on both ends for pivoting. These types of cylinders are designed to carry shear loads and

the trunnion and pivot pins should be carried by bearings that are rigidly held and closely fit for the entire length of the pin.

FOR PACKAGE AND MOUNTING DIMENSIONS SEE TABLES 1 AND 2

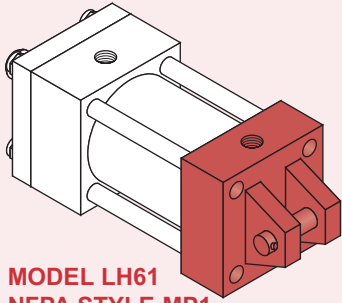

**MODEL LH61
NFPA STYLE MP1**

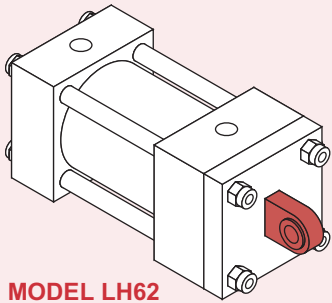
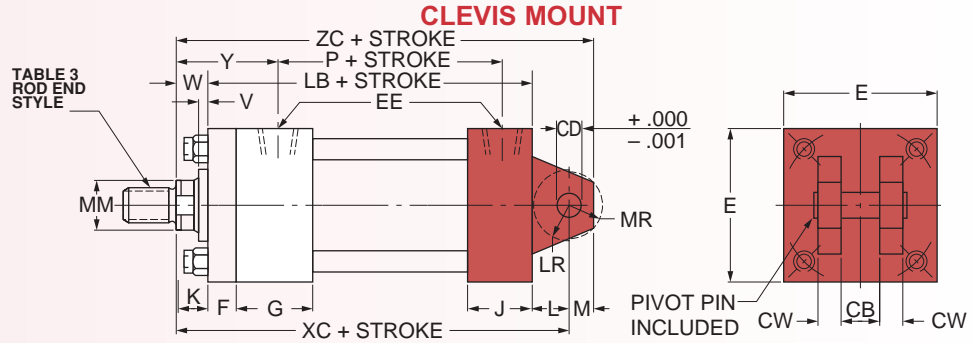

MODEL LH62

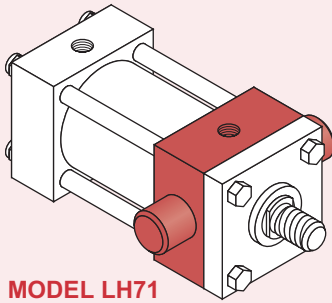
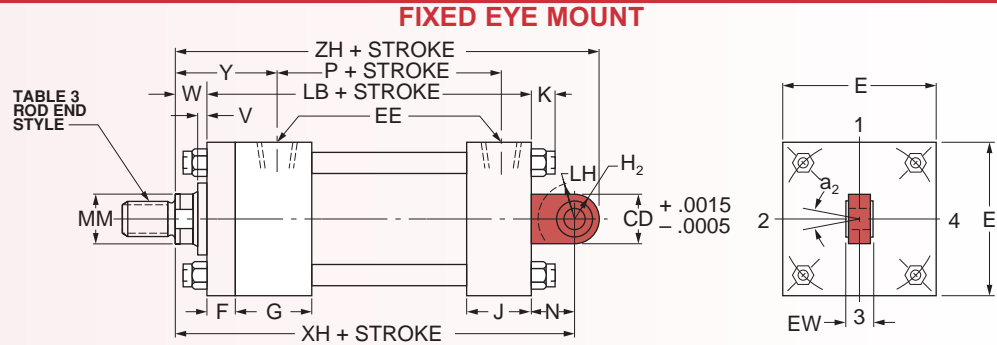

**MODEL LH71
NFPA STYLE MT1**

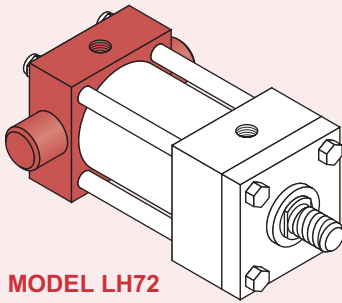
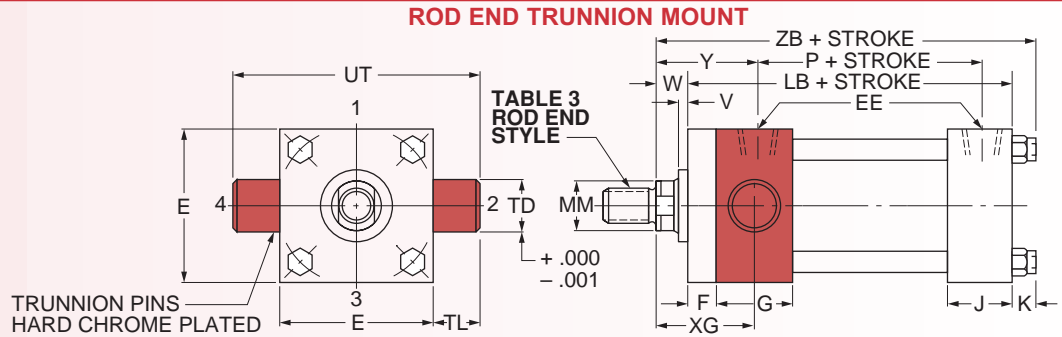

**MODEL LH72
NFPA STYLE MT2**

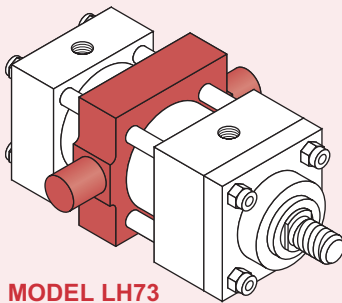
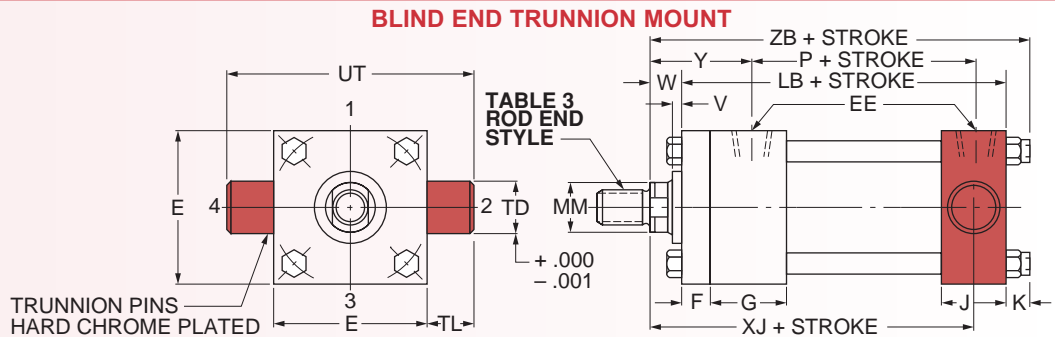

**MODEL LH73
NFPA STYLE MT4
10LH**

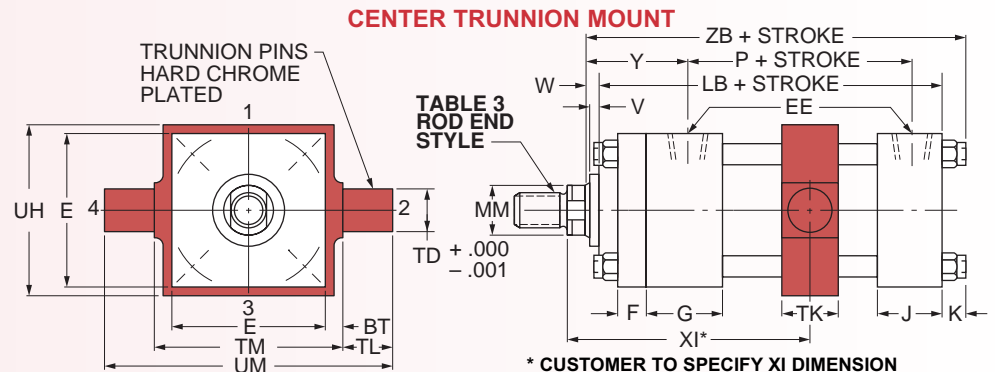

PIN AND TRUNNION MOUNTS

Dimensional Data

TABLE 1 The dimensions given on this table are affected by the piston rod diameter and the stroke.

BORE DIA.	ROD MM	CYLINDER CODE #	LB	P	V	W	XC	XG	XH	XJ	Y	ZB	ZC	ZH
1 1/2	5/8	LH051	4	2 1/4	1/4	5/8	5 3/8	1 3/4	5 1/2	4 1/8	1 15/16	5	5 7/8	6 1/4
	•1*	LH052			1/2	1	5 3/4	2 1/8	5 7/8	4 1/2	2 5/16	5 3/8	6 1/4	6 5/8
2	5/8	LH510	4	2 1/4	1/4	5/8	5 3/8	1 3/4	5 1/2	4 1/8	1 15/16	5 1/16	5 7/8	6 1/4
	1	LH511			1/2	1	5 3/4	2 1/8	5 7/8	4 1/2	2 5/16	5 7/16	6 1/4	6 5/8
	•1 3/8*	LH512			5/8	1 1/4	6	2 3/8	6 1/8	4 3/4	2 9/16	5 11/16	6 1/2	6 7/8
2 1/2	5/8	LH520	4 1/8	2 3/8	1/4	5/8	5 1/2	1 3/4	5 5/8	4 1/4	1 15/16	5 3/16	6	6 3/8
	1	LH521			1/2	1	5 7/8	2 1/8	6	4 5/8	2 5/16	5 9/16	6 3/8	6 3/4
	1 3/8	LH522			5/8	1 1/4	6 1/8	2 3/8	6 1/4	4 7/8	2 9/16	5 13/16	6 5/8	7
	•1 3/4*	LH523			3/4	1 1/2	6 3/8	2 5/8	6 3/8	5 1/8	2 13/16	6 1/16	6 7/8	7 1/8
3 1/4	1	LH530	4 7/8	2 5/8	1/4	3/4	6 7/8	2 1/4	6 7/8	5	2 7/16	6 1/8	7 5/8	8 1/8
	1 3/8	LH531			3/8	1	7 1/8	2 1/2	7 1/8	5 1/4	2 11/16	6 3/8	7 7/8	8 3/8
	1 3/4	LH532			1/2	1 1/4	7 3/8	2 3/4	7 3/8	5 1/2	2 15/16	6 5/8	8 1/8	8 5/8
	2*	LH533			1/2	1 3/8	7 1/2	2 7/8	7 1/2	5 5/8	3 1/16	6 3/4	8 1/4	8 3/4
4	1	LH540	4 7/8	2 5/8	1/4	3/4	6 7/8	2 1/4	6 7/8	5	2 7/16	6 1/8	7 5/8	8 1/8
	1 3/8	LH541			3/8	1	7 1/8	2 1/2	7 1/8	5 1/4	2 11/16	6 3/8	7 7/8	8 3/8
	1 3/4	LH542			1/2	1 1/4	7 3/8	2 3/4	7 3/8	5 1/2	2 15/16	6 5/8	8 1/8	8 5/8
	2	LH543			1/2	1 3/8	7 1/2	2 7/8	7 1/2	5 5/8	3 1/16	6 3/4	8 1/4	8 3/4
	2 1/2*	LH544			5/8	1 5/8	7 3/4	3 1/8	7 3/4	5 7/8	3 5/16	7	8 1/2	9
5	1	LH550	5 1/8	2 7/8	1/4	3/4	7 1/8	2 1/4	7 1/8	5 1/4	2 7/16	6 7/16	7 7/8	8 3/8
	1 3/8	LH551			3/8	1	7 3/8	2 1/2	7 3/8	5 1/2	2 11/16	6 11/16	8 1/8	8 5/8
	1 3/4	LH552			1/2	1 1/4	7 5/8	2 3/4	7 5/8	5 3/4	2 15/16	6 15/16	8 3/8	8 7/8
	2	LH553			1/2	1 3/8	7 3/4	2 7/8	7 3/4	5 7/8	3 1/16	7 1/16	8 1/2	9
	2 1/2	LH554			5/8	1 5/8	8	3 1/8	8	6 1/8	3 5/16	7 5/16	8 3/4	9 1/4
	3	LH555			5/8	1 5/8	8	3 1/8	8	6 1/8	3 5/16	7 5/16	8 3/4	9 1/4
	3 1/2*	LH556			5/8	1 5/8	8	3 1/8	8	6 1/8	3 5/16	7 5/16	8 3/4	9 1/4
6	1 3/8	LH560	5 3/4	3 1/8	1/4	7/8	8 1/8	2 5/8	8 1/4	5 7/8	2 13/16	7 3/16	9 1/8	10
	1 3/4	LH561			3/8	1 1/8	8 3/8	2 7/8	8 1/2	6 1/8	3 1/16	7 7/16	9 3/8	10 1/4
	2	LH562			3/8	1 1/4	8 1/2	3	8 5/8	6 1/4	3 3/16	7 9/16	9 1/2	10 3/8
	2 1/2	LH563			1/2	1 1/2	8 3/4	3 1/4	8 7/8	6 1/2	3 7/16	7 13/16	9 3/4	10 5/8
	3	LH564			1/2	1 1/2	8 3/4	3 1/4	8 7/8	6 1/2	3 7/16	7 13/16	9 3/4	10 5/8
	3 1/2	LH565			1/2	1 1/2	8 3/4	3 1/4	8 7/8	6 1/2	3 7/16	7 13/16	9 3/4	10 5/8
	4	LH566			1/2	1 1/2	8 3/4	3 1/4	8 7/8	6 1/2	3 7/16	7 13/16	9 3/4	10 5/8

HOW TO ORDER

For ordering information refer to Page 23LH

NOTES:

- # For double rod end cylinders, the cylinder code number is to be written with the letter D. (Refer to page 20LH.)
- Available with fixed-nonadjustable cushions on rod end and standard adjustable cushions on the blind end only.
- * Removable retainer not available for these bore and rod combinations: LH61 and LH73 mounting styles.

PORTS:

Series LH Cylinders are supplied with NPTF tapered pipe threads as standard. The largest size port is provided that can be accommodated by the rod and blind end caps in any given bore size. For further information on different types of ports or oversized ports, refer to page 14LH.

CUSHIONS:

The longest cushion is provided that can be accommodated by the rod and blind end caps in any given bore size. Longer cushions are available; for further information, consult the factory.

SEE TABLE 3 PAGE 12LH FOR ROD END STYLES AND DIMENSIONS

TABLE 2 The dimensions are constant regardless of rod diameter or stroke.

BORE DIA.	a ₂	BT	CB	CD	CW	E	EE	EW	F	G	H ₂	J	K	L	LH	LR	M	MR	N	TD	TK	TL	TM	UH	UM	UT
1 1/2	13°	3/4	3/4	1/2	1/2	2	3/8	5/8	3/8	1 1/2	1 3/16	1	3/8	3/4	5/8	5/8	1/2	2 1/32	7/8	1	1 1/8	1	3 1/2	2 3/8	5 1/2	4
2	13°	3/4	3/4	1/2	1/2	2 1/2	3/8	5/8	3/8	1 1/2	1 3/16	1	7/16	3/4	5/8	5/8	1/2	1 1/16	7/8	1	1 1/8	1	4	2 7/8	6	4 1/2
2 1/2	13°	3/4	3/4	1/2	1/2	3	3/8	5/8	3/8	1 1/2	1 3/16	1	7/16	3/4	5/8	5/8	1/2	1 1/16	7/8	1	1 1/8	1	4 1/2	3 3/8	6 1/2	5
3 1/4	13°	3/4	1 1/4	3/4	5/8	3 3/4	1/2	7/8	5/8	1 3/4	1 1/4	1 1/4	1/2	1 1/4	1	1 1/16	3/4	1 5/16	1 1/4	1	1 1/4	1	5 1/4	4 1/8	7 1/4	5 3/4
4	13°	3/4	1 1/4	3/4	5/8	4 1/2	1/2	7/8	5/8	1 3/4	1 1/4	1 1/4	1/2	1 1/4	1	1 1/16	3/4	1 5/16	1 1/4	1	1 1/4	1	6	5	8	6 1/2
5	13°	3/4	1 1/4	3/4	5/8	5 1/2	1/2	7/8	5/8	1 3/4	1 1/4	1 1/4	9/16	1 1/4	1	1 1/16	3/4	1 5/16	1 1/4	1	1 1/4	1	7	6	9	7 1/2
6	12 1/2°	1	1 1/2	1	3/4	6 1/2	3/4	1 3/8	3/4	2	1 3/4	1 1/2	9/16	1 1/2	1 1/4	1 1/4	1	1 3/16	1 5/8	1 3/8	1 1/2	1 3/8	8 1/2	7	11 1/4	9 1/4

Caution –

When ordering replacement cylinders for competitive brands, our Style No. 1 Rod Ends may not be interchangeable with other manufacturer's Style No. 1. Our Style No. 2 should be used if this applies to your application.

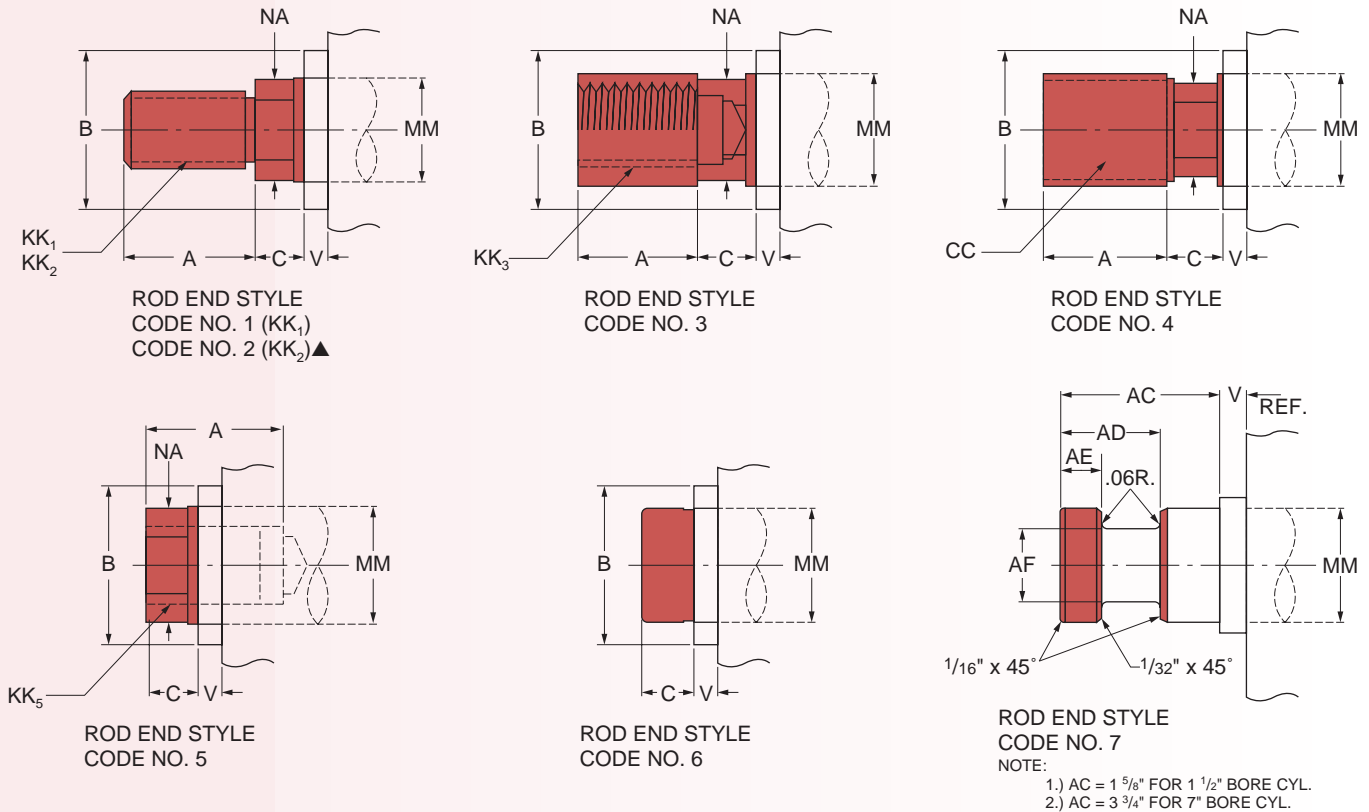

TABLE 3 Piston rod end styles.

ROD MM	A	B ^{-.001 -.003}	C	CC	*D	KK -1-	KK ▲ 2-3-5	NA	AD	AE ^{+.000 -.002}	AF DIA.	AC
5/8	3/4	1 1/8	3/8	5/8-18	1/2	1/2-20	7/16-20	19/32	5/8	1/4	3/8	1 1/8
1	1 1/8	1 1/2	1/2	1-14	7/8	7/8-14	3/4-16	31/32	15/16	3/8	11/16	1 1/2 (#1)
1 3/8	1 5/8	2	5/8	1 3/8-12	1 1/8	1 1/4 -12	1-14	1 11/32	1 1/16	3/8	7/8	1 3/4
1 3/4	2	2 3/8	3/4	1 3/4-12	1 1/2	1 1/2 -12	1 1/4 -12	1 45/64	1 5/16	1/2	1 1/8	2
2	2 1/4	2 5/8	7/8	2-12	1 11/16	1 3/4 -12	1 1/2 -12	1 61/64	1 11/16	5/8	1 3/8	2 5/8
2 1/2	3	3 1/8	1	2 1/2-12	2 1/16	2 1/4 -12	1 7/8 -12	2 29/64	1 15/16	3/4	1 3/4	3 1/4
3	3 1/2	3 3/4	1	3-12	2 5/8	2 3/4 -12	2 1/4 -12	2 15/16	2 7/16	7/8	2 1/4	3 5/8 (#2)
3 1/2	3 1/2	4 1/4	1	3 1/2-12	3	3 1/4 -12	2 1/2 -12	3 7/16	2 11/16	1	2 1/2	4 3/8
4	4	4 3/4	1	4-12	3 3/8	3 3/4 -12	3 -12	3 15/16	2 11/16	1	3	4 1/2

* Distance Across Wrench Flats

** Other rod sizes available. Consult Factory.

▲ Rod end style KK₂ is studded as standard for 5/8" and 1" dia. rods.
Studded rod end style is available for all rod sizes.

Design options

Special Cylinders

Milwaukee Cylinder has two basic identities as a cylinder producer. The first, as a supplier of standard Hydraulic and Air Cylinders. The second as a specialist in the design and manufacture of totally unique cylinders to suit the wide range of applications for cylinders being developed into today's industry. **Milwaukee** is a customer and engineering orientated company which gladly welcomes a challenge to meet every customer's unique needs in the area of specials. For information on what data is required by **Milwaukee** to develop a design to suit your needs, contact either your local **Milwaukee** representative or the factory.

Special Rod Ends

Modifications of standard or entirely special rod ends are available from **Milwaukee** at a slightly additional charge. When your requirements call for a special rod end style, your order should include a sketch if it is to be an entirely special rod end or note reference as to which letter dimensions you wish to have modified (ref. pgs. 4LH-12LH and 23LH).

Special Assemblies from Standard Parts

This catalog was designed to aid in communication and simplify the placing of orders by our customers. On pages 4LH-12LH and 23LH, each style of the various standard cylinder mountings is illustrated, using the commonly recognized cylinder dimensional symbols of the National Fluid Power Association. Each side of the end views are numbered to aid in communication when referring to the relationship between the ports and the mountings. When requesting information or placing an order that requires a dimension other than standard, always make reference to the given dimensional symbol in the catalog and then give your requirements.

Combined Mountings

Standard mountings may be combined when specified by the customer. Some examples of this are:

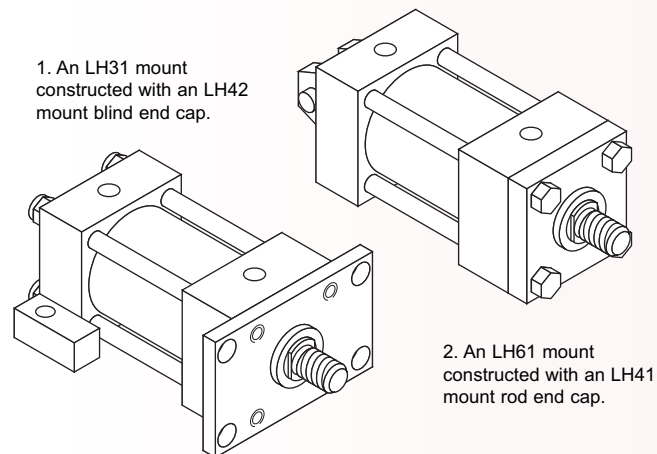

These and other combinations can be readily made from standard parts. If you are unsure of a possible combination or if it will suit your particular needs, consult with your local **Milwaukee** representative or contact the factory.

Cushion Adjustment Locations

A ball check is supplied as standard in position #4 and a cushion adjustment needle is supplied as standard in position #2 on most models. The cushion needle and ball check are interchangeable as far as location and may be put in any side not occupied by a port or mounting.

Port Locations

Ports are located in position #1 as standard unless otherwise specified by the customer. By using the position numbers given with the end views in the dimensional data section of this catalog, ports can be arranged in any one of four 90° positions in relation to the cylinder mounting without charge. When ports are relocated on a cushioned cylinder, the cushion needle and ball check are automatically relocated to hold their relationship to the port as on a standard cylinder, unless otherwise specified at the time of the order.

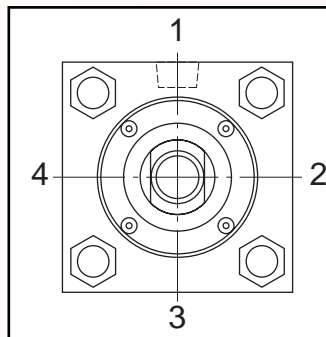

Removable Trunnion Pins

Removable trunnion pins are available on models LH71 & LH72 at a nominal extra charge. They can be used on all bore and rod combinations, except on the largest oversize rods offered with each bore size on all model LH71 cylinders.

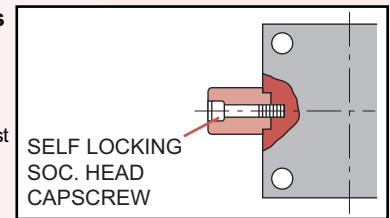

CAUTION: Cylinders with removable trunnion pins will have a reduced pressure rating. Consult the factory.

Single Acting Cylinders

The **Milwaukee** Series LH Cylinders are designed for either single or double action. When used as a single acting cylinder, hydraulic power drives the piston in one direction, only relying on either the load or an external force to return the piston after the pressure is exhausted.

Single Acting-Spring Cylinders

Single acting spring return cylinders normally have a spring inside of the cylinder to return the piston to its original position. The application load and friction conditions must be specified when placing an order to properly size the spring. Also specify whether the spring is to return or advance the piston. A spring return cylinder is designed with a stop tube to act as spring guide, which prevents binding of the cylinder due to misalignment of the spring. To accurately determine the cylinder length and mounting dimensions for your application, contact your local **Milwaukee** representative or the factory.

Water Service Cylinders

Milwaukee Series LH Cylinders can be used with water as an operating fluid with some standard modifications to the types of material and the manufacturing processes used. These modifications will include, at some additional cost, bronze piston, nickel plated end caps, a hard chrome plated cylinder barrel and a chrome plated piston or stainless steel piston rod at extra cost. Due to the increased factors of corrosion, electrolysis and mineral deposits acting within a water fitted cylinder, **Milwaukee** cannot warrant or make any guarantees other than a water service cylinder will be free of defects in workmanship or materials.

Proximity Switches

End of Stroke Limit Switches:

We provide inductive proximity switches for end of stroke sensing. These non-contact switches detect the presence of the spud/cushion bushing.

Designed for up to 3000 PSI hydraulic systems, as well as pneumatic applications. Available on the A, LH and H Series cylinders.

The switches are two wire devices with N.O. "contacts" rated for 20-230 V AC/DC. The electrical interface is a 3-pin mini receptacle.



Adjustable Stroke Cylinders

When a cylinder application requires stroke adjustment, **Milwaukee** offers a number of designs, the most common of which is illustrated below. This particular design is externally adjustable, incorporating a threaded rod (of piston rod quality) with the standard hydraulic rod end multiple lip vee seal and bushing design. This provides a proven-effective high and low pressure seal, affording maximum sealing on the stroke adjustment rod.

Further information concerning design limitations, cushioning or alternate designs can be obtained by contacting the factory.

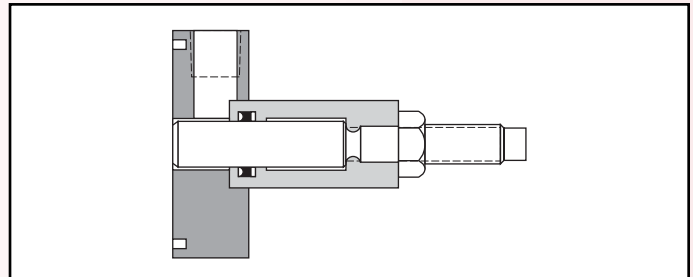

Design Options

Standard Ports

The **Milwaukee** Series LH Cylinders are manufactured as standard, with NPTF tapered thread ports of the largest size that will fit in both the rod and blind ends of a given bore size. Upon request, extra ports can be provided on the sides of the end caps not occupied by mountings or cushion adjusters.

Oversize Ports

On most bore sizes, welded bosses may be provided for oversize NPTF ports. These bosses protrude from the sides of the end caps. For information as to the boss height in relation to your bore and port requirements, contact your local **Milwaukee** Representative. Also, special end caps can be provided, at additional cost, which are heavier so that oversize ports can be accommodated without the use of a welded boss.

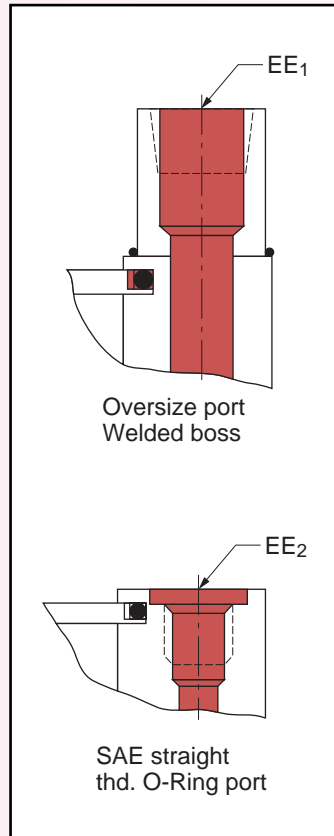

Straight Thread Ports

On request, **Milwaukee** will furnish an SAE straight thread O-Ring port with its Series LH Cylinders. In addition to the standard oversize NPTF ports, welded bosses may also be used for oversize SAE straight thread O-Ring ports. For further information on oversize SAE ports, contact the factory.

Note:

Flange and manifold style ports are available from **Milwaukee** at a slightly additional charge.

Rod Boots

When cylinders are used in areas of high contamination or where contaminants have an air hardening property, the exposed piston rod should be covered with a rod boot to protect the rod bearing and seals. A rod boot is simply a collapsible cover used for such an application. It is of sewn construction made from a neoprene coated fabric. The rod boots are impervious to oil, grease and water. They will operate effectively from 0°F to +200°F without cracking.

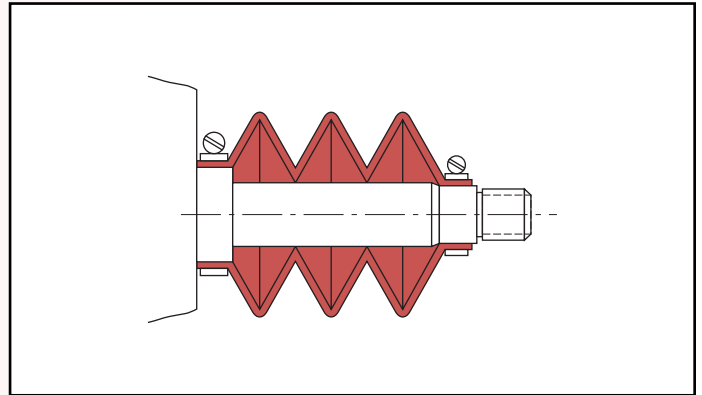

Metallic Rod Wipers

Metallic rod wipers will be supplied in place of the standard synthetic rubber wiper when specified at the time of order. This type of seal is recommended for applications where contaminants would tend to cling to the rod and damage a standard synthetic rubber rod wiper.

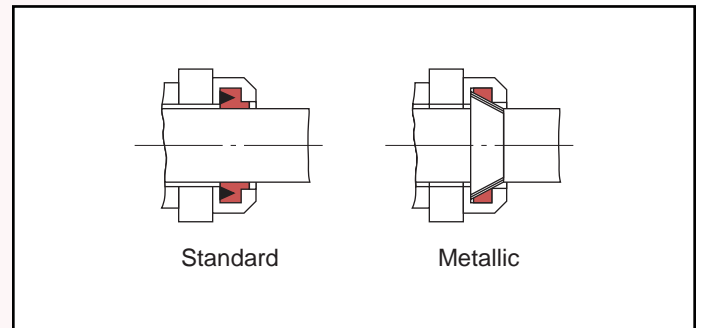

BORE DIA.	STD. NPTF PORT EE	OVERSIZE NPTF PORT EE ₁	SAE STRAIGHT O-RING PORT	
			EE ₂	SAE STR. THD. SERIES
1½	3/8	1/2	#6	9/16-18
2	3/8	1/2	#6	9/16-18
2½	3/8	1/2	#6	9/16-18
3¼	1/2	¾	#10	7/8-14
4	1/2	¾	#10	7/8-14
5	1/2	¾	#10	7/8-14
6	¾	1	#12	1½-12

Cylinder Force and Speed

Hydraulic Cylinder Force

Table 7 on page 17LH shows the thrust force developed by various bore diameters when working at various pressures. These figures do not include a factor covering a reduction in force due to seal or packing friction in the cylinder. This type of friction is estimated to affect the cylinder thrust force by 10%. Additional pressure must be developed by the pump, not only to overcome frictional loss, but also flow losses in the circuitry. The engineer should realize that the useable pressure in the cylinder may be from 10% to 25% less than the pump and relief valve gauge reading

Hydraulic Cylinder Speed

Figures shown in the body of this chart are cylinder rod travel speeds in inches per minutes. The extension speeds represent the net piston area for the various rod diameters shown.

HYDRAULIC CYLINDER SPEEDS

PISTON DIA.	ROD DIA.	1 GPM	3 GPM	5 GPM	8 GPM	12 GPM	15 GPM	20 GPM	25 GPM	30 GPM	40 GPM	50 GPM	75 GPM
1 1/2	None	130	392	654	1034								
	5/8	158	476	792	1265								
	1	235	706	1176	1880								
2	None	73	221	368	588	883	1120						
	1	97	294	490	782	1175	1465						
	1 3/8	139	418	697	1115	1673	2090						
2 1/2	None	47	131	235	376	565	675	940	1175				
	1	56	168	280	448	672	840	1120	1400				
	1 3/8	67	203	339	542	813	1015	1355	1695				
	1 3/4	92	277	463	740	1110	1385	1850	2310				
3 1/4	None	28	83	139	223	334	417	557	696	836	1115		
	1 3/8	34	102	170	271	407	510	680	850	1020	1360		
	1 3/4	39	118	196	313	472	588	784	980	1176	1568		
	2	44	134	224	358	537	672	896	1120	1344	1792		
4	None	18	55	92	147	220	276	368	460	552	736	920	
	1 3/4	22	68	113	182	273	339	452	565	678	904	1130	
	2	24	73	122	196	294	366	488	610	732	976	1220	
	2 1/2	30	90	150	241	362	450	600	750	900	1200	1500	
5	None	12	35	58	94	141	174	232	290	348	464	580	870
	2	14	42	70	112	168	210	280	350	420	560	700	1050
	2 1/2	16	47	78	125	188	235	315	390	470	630	780	1170
	3	18	55	92	147	220	275	365	460	550	730	920	1380
	3 1/2	22	66	111	178	266	333	444	555	665	888	1110	1665
6	None	8	24	41	65	98	123	162	202	245	320	405	606
	2 1/2	10	30	50	79	118	150	200	250	300	400	495	750
	3	11	33	54	87	130	165	206	270	325	435	545	810
	3 1/2	12	37	62	99	148	185	245	310	370	495	615	830
	4	15	44	73	117	176	220	295	365	440	585	735	1095

Stop Tube

Stop tubes are used to maintain bearing pressure within acceptable limits and are recommended on cylinders with long strokes or poorly guided rods.

The stop tube is a spacer between the rod end cap and the piston, which provides separation between the piston and the rod bearing. This separation reduces the moment forces developed between the rod bearing and piston when the rod is extended.

To determine if stop tube is necessary for your cylinder requirements, you have to solve for "K" (refer to table 4). If your required cylinder has a "K" dimension in excess of 40 inches, stop tube is required. For each 10 inch increment or fraction thereof in excess of 40 inches, one inch of stop tube is recommended. When stop tube is required, the overall length of the cylinder will be increased by the length of the stop tube to be used.

To Determine "K" (refer to Table #4)

*note: W = the rod stick out (refer to pages 5LH thru 11LH)

Cylinder #1, #4, #8 – from Table 4

$$K = 4L = 4 (\text{stroke} + W^*)$$

Cylinder #2 - from Table 4

$$K = L = (\text{CA or CE}) + \text{XG} + \text{Stroke}$$

note: CA = rod eye dimension page 24LH
CE = rod clevis dimension page 24LH
XG = mounting dimension page 11LH

Cylinder #3 – from Table 4

$$K = L = W^* + \text{Stroke}$$

Cylinder #5 – from Table 4

$$K = L = (\text{CA or CE}) + \text{XC} + (2 \times \text{Stroke})$$

note: CA = rod eye dimension page 24LH
CE = rod clevis dimension page 24LH
XC = mounting dimension page 11LH

Cylinder #6 – from Table 4

$$K = L = (\text{CA or CE}) + \text{XJ} + (2 \times \text{Stroke})$$

note: CA = rod eye dimension page 24LH
CE = rod clevis dimension page 24LH
XJ = mounting dimension page 11LH

Cylinder #7 – from Table 4

$$K = L/2 = (W^* + \text{Stroke})/2$$

Note: Stop tube length must be added to "K" factor before making final selection of rod size. This is primarily true in No. 5 long stroke applications.

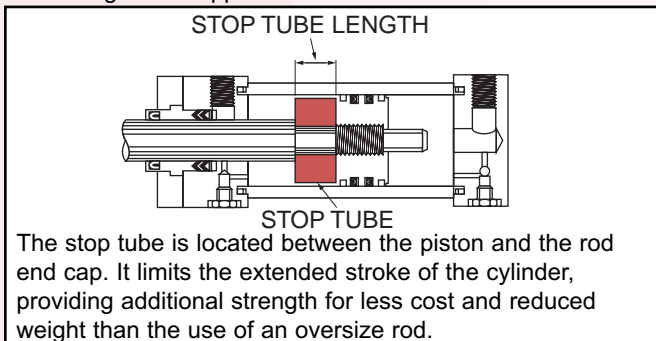
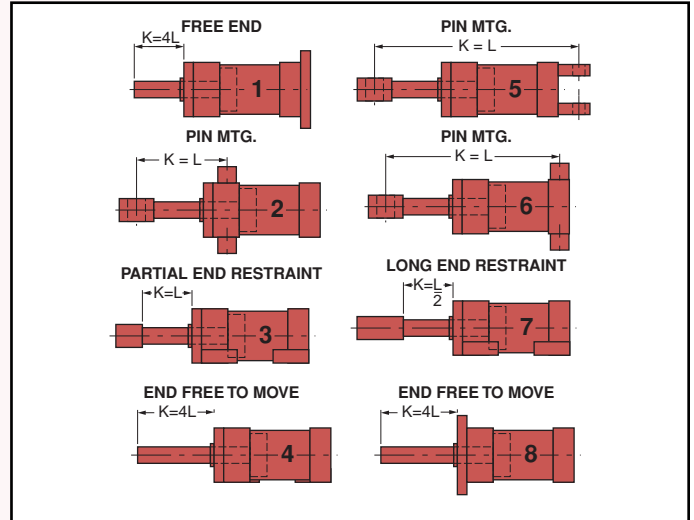

TABLE 4 Stroke to mounting relationship – All rods in extended position.



When mounting long stroke cylinders, care should be taken to assure cylinder alignment over the entire length of stroke. The use of external guides or swivel bushings is recommended to reduce side load conditions and prolong the cylinder's service life.

TABLE 5 Value of "K" in inches

THRUST FORCE In. Lbs.	PISTON ROD DIAMETER												
	5/8"	1"	1 3/8"	1 3/4"	2"	2 1/2"	3"	3 1/2"	4"	4 1/2"	5"	5 1/2"	
400	35	84	134										
700	30	68	119										
1,000	26	60	105	156	190								
1,400	24	54	93	144	175	244	308						
1,800	23	48	84	127	160	230	294	366					
2,400	18	45	75	114	145	214	281	347					
3,200	16	40	68	103	131	196	262	329	398				
4,000	12	38	63	93	119	174	240	310	373	446			
5,000	9	36	60	87	112	163	225	289	359	426			
6,000		30	56	82	102	152	209	274	342	411	476		
8,000		25	51	76	93	136	186	244	310	375	448		
10,000		21	45	70	89	125	172	221	279	349	412		
12,000		17	41	64	85	117	155	210	270	326	388	455	
16,000			35	57	75	110	141	188	233	291	350	421	
20,000			28	52	66	103	136	173	218	270	325	385	
30,000				39	56	87	120	156	190	232	285	330	
40,000					24	43	75	108	142	177	210	248	293

Rod Size Selection

Milwaukee Hydraulic Cylinders incorporate a high strength, surface hardened rod. Standard rod sizes are generally suitable for most applications. However, on long stroke or high thrust applications, the selection of minimum rod size should be checked using the following steps:

1. Knowing bore size, stroke and push thrust (refer to Table No. 7 below), determine the overall length between mounting points, Table 1, pages 5LH-11LH. Equate determined overall length to "L."
2. Select from Table 2, pages 5LH-11LH, the type mounting being used and determine the equivalent length dimension "K." (Refer to page 16LH.)
3. Refer to Table 5, page 16LH and, using the thrust load and developed "K" dimension, select rod size.
4. If oversize rod is required, re-check overall length dimensions as determined in step No. 1. There will be a slight change which generally will not affect the "Size Determination" calculations, but must be considered in the cylinder installation.

TABLE 6 Deductions for pull stroke force and displacement

ROD SIZE	ROD AREA SQ. IN.	CYLINDER FORCE IN POUNDS FOR VARIOUS PRESSURES							DISPLACEMENT PER INCH OF STROKE	
		100	250	500	750	1000	1250	1500	CU. IN.	GALLONS
5/8	.307	31	77	155	232	310	387	465	.307	.0013
1	.785	79	197	395	592	790	987	1,185	.785	.0034
1 3/8	1.485	149	372	745	1,117	1,490	1,862	2,230	1.485	.0064
1 3/4	2.405	241	601	1,203	1,804	2,410	3,011	3,613	2.405	.0104
2	3.142	314	785	1,570	2,355	3,140	3,925	4,710	3.142	.0136
2 1/2	4.909	491	1,227	2,455	3,682	4,910	6,137	7,365	4.909	.0213
3	7.069	707	1,767	3,535	5,302	7,070	8,837	10,605	7.069	.0306
3 1/2	9.621	962	2,405	4,810	7,215	9,620	12,025	14,430	9.621	.0416
4	12.566	1,257	3,142	6,285	9,427	12,570	15,712	18,855	12.566	.0544
4 1/2	15.904	1,590	3,975	7,950	11,925	15,900	19,875	23,850	15.904	.0688
5	19.635	1,964	4,910	9,820	14,730	19,640	24,550	29,460	19.635	.0850
5 1/2	23.758	2,376	5,940	11,880	17,820	23,760	29,700	35,640	23.758	.1028

NOTE:

To determine cylinder pull stroke force or displacement, deduct force or displacement corresponding to rod size in Table 6 from force or displacement corresponding to bore size shown in Table 7.

1 gallon = 231 Cu. In.
 Area of Circle = .7854 d²

Piston Speed (In./Min.) = $\frac{\text{Pressure Source Delivery (GPM)}}{\text{Cylinder Displacement (Gal./In.)}}$

PIPING:

All pipes should be free from dirt, scale, rust and threads de-burred. Seamless steel tubing makes an installation superior to piping, as it is cleaner and leakproof.

TABLE 7 Thrust force and displacement

BORE SIZE	PISTON AREA SQ. IN.	CYLINDER FORCE IN POUNDS FOR VARIOUS PRESSURES							DISPLACEMENT PER INCH OF STROKE	
		100	250	500	750	1000	1250	1500	CU. IN.	GALLONS
1 1/2	1.767	177	442	884	1,325	1,767	2,209	2,650	1.767	.00765
2	3.142	314	785	1,571	2,357	3,142	3,928	4,713	3.142	.0136
2 1/2	4.909	491	1,227	2,455	3,682	4,909	6,137	7,364	4.909	.0213
3 1/4	8.296	830	2,075	4,148	6,222	8,296	10,370	12,444	8.296	.0359
4	12.566	1,257	3,142	6,283	9,425	12,566	15,708	18,849	12.566	.0544
5	19.635	1,964	4,910	9,818	14,726	19,635	24,544	29,452	19.635	.0850
6	28.274	2,827	7,067	14,137	21,206	28,274	35,342	42,411	28.274	.1224

TABLE 8 LH Series pressure rating

BORE SIZE	1 1/2	2	2 1/2	3 1/4	4	5	6
Pressure Rating	1500	1500	1500*	1500	1000	1000*	750

*NOTE: 2 1/2" Bore, 5/8" Rod, Rating 1000 PSI
 5" Bore, 1" Rod, Rating 750 PSI

INSTALLATION & MAINTENANCE NOTES

STORAGE

Often times, cylinders are delivered before a customer is prepared to install them and must be stored for a period of time. When storage is required, the following procedure should be employed:

1. Select an area indoors for storage, which has dry and non-corrosive atmosphere. Take caution to protect the cylinder from both internal and external corrosion.
2. Cylinders to be stored should be kept in a vertical position (piston rod up) whenever possible.
3. Port protector plugs should be kept in the cylinder ports until the time of installation.

INSTALLATION

General Information

1. Cleanliness –
The most important consideration when installing the cylinder. When cylinders are shipped from Milwaukee, the ports are securely plugged with plastic plugs which should not be removed until the piping is to be installed. All piping should be thoroughly clean, to include the removal of all threading and flaring burrs or chips, before making the connection to the cylinder ports. One chip can cause premature failure of the cylinder or other hydraulic system components.
2. Alignment –
Improper alignment will result in excessive cylinder wear. Check to assure rod alignment between the cylinder and its mating component on your machine in both the extended and retracted positions.
3. Environment –
Cylinders operating in areas where there is weld splatter, fast drying chemicals, paint, excessive heat or other hazardous conditions, should have covers or shields to prevent damage to the rod and rod seals.
4. Bleeding –
Air within the cylinder or system will cause erratic operation of the cylinder. Milwaukee Cylinders generally do not require bleed ports if the cylinder ports are mounted in an upright position. Several full strokes of the cylinder will purge air from the cylinder into the circuit piping, where it can be bled off. Bleeder ports are available for applications where the cylinder is the high point of the circuit or where the cylinder does not complete a full stroke during its normal cycle.

Mounting Recommendations

1. Foot Mounted Cylinders –
The use of high strength alloy steel mounting bolts 1/16" smaller than the hole size is recommended. After final alignment, foot mounted cylinders should be dowel pinned in place.
2. Trunnion Mounted Cylinders –
Lubricated pillow blocks designed for close tolerance applications should be used. It is important to rigidly mount and align the pillow blocks so that the trunnion pins will not be subjected to any extreme bending moments. The rod end should be pivoted with the pivot pin in line and parallel to the axis of the trunnion pins.
3. Flush Mount Cylinders –
The use of high strength alloy steel mounting bolts is recommended. Shear keys should be used to reduce the stress on the mounting bolts created by the normal push and pull forces created by the cylinder cycle.
4. Flange Mount Cylinders –
The controlled diameter rod bushing extension can be used as a pilot to locate the flange mount. Dowel pins should be used after the cylinder is mounted and aligned to prevent shifting.
5. Clevis Mount Cylinders –
This type of cylinder must be pivoted at both ends and the pins must be in line and parallel to each other. After the cylinder is mounted, the customer should check to assure that the cylinder is free to swing through its working arc without interference from other machined parts.

CYLINDER TROUBLE SHOOTING

1. External leakage –
If leaking occurs between the end cap and barrel, check tie-rod torque. If the torque is correct, then replace the barrel seal. When leakage occurs in the rod bushing area, the rod seals should be replaced. If leakage continues or reoccurs in short period of operation, check items 2 thru 5.
2. Cylinder misalignment –
Side load is a common problem which occurs when the cylinder application does not allow the piston rod to work in line during the extend and retract motions of the cylinder. Evidence of this is excessive seal failure, bushing wear or galling of the piston rod. Often, bending of the piston rod or complete failure (breakage) of the rod occurs.
3. Contamination on the piston rod –
Dirt and other material is often picked up when the piston rod is extended. When the rod is retracted in an excessive dirty application, it often carries the dirt back into the rod seal cavity of the cylinder, causing damage to the seals. With a slight modification of the cylinder rod end, a rod boot can be added to protect the rod bushing and seals for most applications.
4. Bad mountings –
Due to wear of pivot pins or mounting bolts working loose, a cylinder may have side load, even though the rod was in line when the cylinder was first installed. All cylinder mountings should be checked periodically.
5. Damaged piston rod –
An extended piston rod can be damaged by the impact of a hard object which could burr the rod. If this occurs, the rod should be checked immediately to prevent seal damage.
6. Internal leakage –
Inside the cylinder, leakage past the piston seals can cause sluggish movement or settling of the cylinder under load conditions. This occurs due to leakage of worn piston seals or rings.
7. Creeping cylinder –
When a cylinder is stopped in midstroke and it creeps, check for internal leakage. Creeping can also be caused by a worn control valve and this should be checked, even if the cylinder is found to have internal leakage.
8. Erratic operation –
When a cylinder is erratic or sluggish in operation, this may be caused by a number of problems. The most common cause of sluggish operation is air in the system. Internal leakage could also be a cause. If the system starts out sluggishly and, as it warms, speeds up, the oil may be of too high viscosity. The whole system should be checked for worn components if after these checks, the cylinder is still operating in a sluggish manner.

CYLINDER MAINTENANCE

Rod Seal Replacement

When changing rod seals, extend the piston rod 3" or more if possible, being sure to support the rod at all times. Remove the retainer plate screws (if tie-rod nuts have to be removed, refer to the nut torque specification on this page when reassembling the cylinder), retainer plate and outer bushing. Using an eye hook or thin screwdriver, pry the vees from the end cap cavity (if low pressure air is applied to the rod end port, this will help to force the vees from the cavity). The new set of vees should be assembled into the cavity separately and lubed with the soft vee in the center. Replace the rod wiper in the bushing and reassemble the cylinder.

Piston Seal Replacement

When changing piston seals, extend the piston rod 3" or more if possible, being sure to support the piston rod and the piston at all times. *Remove the tie-rod nuts, blind end cap, the barrel and then the piston seals. A light grease, compatible with the system fluid, should be used on the rings and block vee seals for smooth assembly. Install the block vee piston seals, scarf cutting on only the back-up washers. Then install the cast iron rings with the joints in opposite directions. To reassemble, start the piston into the tube, compressing the cast iron rings using twine or a ring compressor. When the piston block vee seal is to the edge of the barrel, use a thin rounded blade to start the lip of the block vee, making sure the entire lip is started before moving the piston further into the tube.

*Note:

When a cylinder has been disassembled this far, the barrel seals should at least be inspected, if not replaced.

Barrel Seal Replacement

When replacing barrel seals, use the same method of disassembling the cylinder as used when replacing piston seals. The barrel seal consists of a backup washer and O-Ring, which is assembled on the first step of both ends of the tube, with the backup washer going on first. The outer diameter of the tube groove on the end caps must be checked for nicks or burrs and then greased. Position the end caps squarely on the tube (check to make sure port location is correct) and firmly force or tap the end cap over the tube until it bottoms. Check to make sure the O-Ring did not shear and then finish assembling the cylinder.

Nut Torque Specifications

When it is necessary to remove the tie-rod nuts on a cylinder, they must be reassembled to the torque specifications given below. To prevent the tie-rods from twisting when tightened, use a vice grip or locking clamp. Note that the torque specification is based on lubricated threads.

CYLINDER BORE	1 1/2	2 – 2 1/2	3 1/4 – 4	5 – 6
TORQUE FT. LBS.	8	18	35	60

INSTALLATION & MAINTENANCE NOTES

DOUBLE ROD END CYLINDERS

Milwaukee's double rod end cylinders are available with all the standard types of mountings, except 61 and 62. When specified by the customer, the standard mountings offered by Milwaukee Cylinder may be combined. Combinations such as a 31 mounting on one end and a 42 mounting on the other can be readily made from standard parts.

To obtain dimensional information on a double rod end cylinder, first select the desired mounting style and refer to the corresponding single rod end cylinder model shown on the preceding pages. After you have determined all necessary dimensions from the previous page covering the desired mounting, turn back to this page. Supplement those dimensions with additional ones from the drawings below and the table at the right. These added dimensions differ from, or are in addition to, those shown on the preceding pages and provide the additional information needed to completely dimension a double rod end cylinder model.

On a double rod end cylinder where two different rod ends are required, or two different rod sizes are required, or cushions on one end are required, be sure to state clearly which rod is to go at which end of the cylinder. When two types of mounting styles are required, be sure to specify their relationship to the piston rods, if they are not the same.

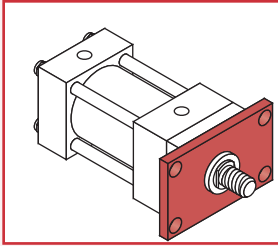

BORE DIA.	ROD MM	CYLINDER CODE #	LD*	SE1*	SS1*	XE1*	ZE1*	ZL	ZM	ZT1*
1 1/2	5/8	D051	4 7/8	6 3/8	3 3/8	6 1/2	6 1/2	5 7/8	6 1/8	6 5/8
	1	D052				6 7/8	6 7/8	6 1/4	6 7/8	6 7/8
2	5/8	D510	4 7/8	6 3/4	3 3/8	6 7/16	6 3/4	5 15/16	6 1/8	6 5/8
	1	D511				6 13/16	7 1/8	6 5/16	6 7/8	7
	1 3/8	D512				7 1/16	7 3/8	6 9/16	7 3/8	7 1/4
2 1/2	5/8	D520	5	7 1/8	3 1/2	6 11/16	7	6 1/16	6 1/4	5 3/4
	1	D521				7 1/16	7 3/8	6 7/16	7	7 1/8
	1 3/8	D522				7 5/16	7 5/8	6 11/16	7 1/2	7 3/8
	1 3/4	D523				7 9/16	7 7/8	6 15/16	8	7 5/8
3 1/4	1	D530	6	7 3/4	3 3/4	7 5/8	8	7 1/4	7 1/2	8 1/8
	1 3/8	D531				7 7/8	8 1/4	7 1/2	8	8 3/8
	1 3/4	D532				8 1/8	8 1/2	7 3/4	8 1/2	8 5/8
	2	D533				8 1/4	8 5/8	7 7/8	8 3/4	8 3/4
4	1	D540	6	8	3 3/4	7 3/4	8 1/8	7 1/4	7 1/2	8 1/8
	1 3/8	D541				8	8 3/8	7 1/2	8	8 3/8
	1 3/4	D542				8 1/4	8 5/8	7 3/4	8 1/2	8 5/8
	2	D543				8 3/8	8 3/4	7 7/8	8 3/4	8 3/4
	2 1/2	D544				8 5/8	9	8 1/8	9 1/4	9
5	1	D550	6 1/4	8 3/8	3 5/8	8 1/16	8 9/16	7 9/16	7 3/4	8 13/16
	1 3/8	D551				8 5/16	8 13/16	7 13/16	8 1/4	9 1/16
	1 3/4	D552				8 9/16	9 1/16	8 1/16	8 3/4	9 5/16
	2	D553				8 11/16	9 3/16	8 3/16	9	9 7/16
	2 1/2	D554				8 15/16	9 7/16	8 7/16	9 1/2	9 11/16
	3	D555								
3 1/2	D556									
6	1 3/8	D560	7	8 7/8	4 1/8	8 7/8	9 3/8	8 7/16	8 3/4	9 11/16
	1 3/4	D561				9 1/8	9 5/8	8 11/16	9 1/4	9 15/16
	2	D562				9 1/4	9 3/4	8 13/16	9 1/2	10 1/16
	2 1/2	D563				9 1/2	10	9 1/16	10	10 5/16
	3	D564								
	3 1/2	D565								
4	D566									

NOTE:

These dimensions are to be substituted for the related mounting dimensions given on the preceding pages. All dimensions given on this table are plus stroke.

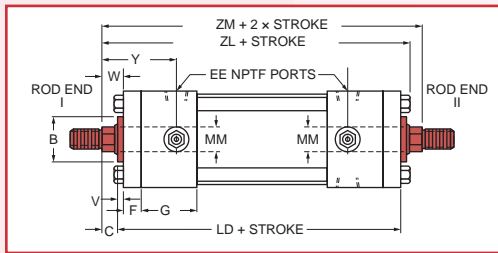

KEY MOUNT CYLINDERS

The Milwaukee Key Mount retainer plate is a mounting option designed to add rugged stability to foot and side mount cylinders. The retainer plate is extended below the

mounting surface of the cylinder. This extension may be fitted into a milled keyway in your mounting pad, eliminating the need for welded keys or locator pins.

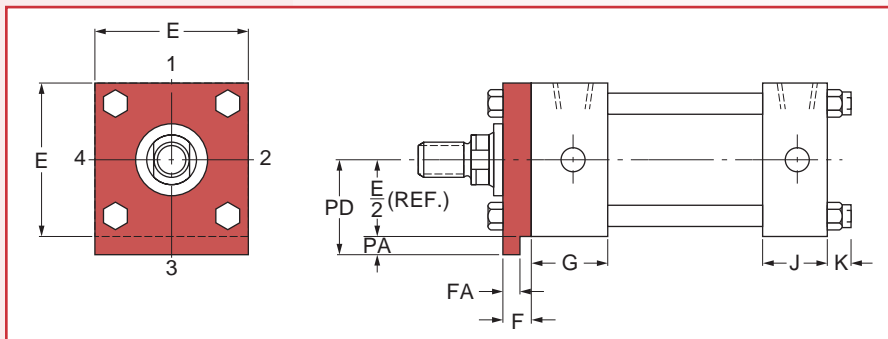

BORE DIA.	E	F	FA	G	PA	PD
1 1/2	2	3/8	.312/.310	1 1/2	3/16	1 3/16
2	2 1/2	3/8	.312/.310	1 1/2	3/16	1 7/16
2 1/2	3	3/8	.312/.310	1 1/2	3/16	1 11/16
3 1/4	3 3/4	5/8	.562/.560	1 3/4	5/16	2 3/16
4	4 1/2	5/8	.562/.560	1 3/4	5/16	2 9/16
5	5 1/2	5/8	.562/.560	1 3/4	5/16	3 1/16
6	6 1/2	3/4	.687/.684	2	3/8	3 5/8

Retainer Plate Capscrew Torques

RETAINER PLATE CAPSCREW TORQUES MODELS LH21 & LH22	
BORE DIA.	TORQUE LBS. FT.
1 1/2	5
2	12
2 1/2	12
3 1/4	30
4	30
5	50
6	50

RETAINER PLATE CAPSCREW TORQUES MODELS LH22, LH32, LH61 & LH73		
BORE DIA.	ROD	TORQUE LBS. FT.
1 1/2	5/8	6
2	5/8	6
	1	15
2 1/2	5/8	6
	1, 1 3/8	15
3 1/4	1, 1 3/8, 1 3/4	15
4	1, 1 3/8, 1 3/4, 2	15
5	1, 1 3/8, 1 3/4, 2	15
	2 1/2, 3	27
6	1, 1 3/8, 1 3/4, 2	15
	2 1/2, 3, 3 1/2, 4	27

Solid State End of Stroke Limit Switches

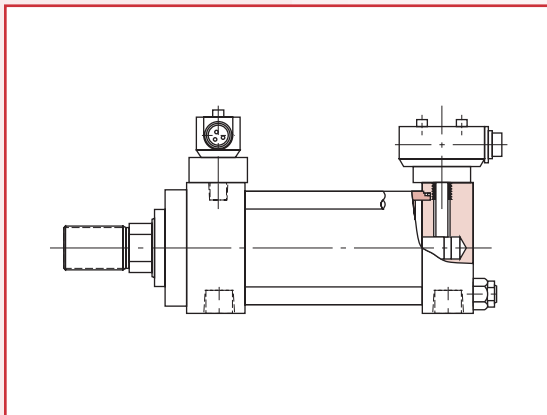

Features:

- End of stroke indication for all sizes of cylinders
- Pneumatic or hydraulic operation (3000 psi)
- Choice of rod end, cap end or both ends
- Cushioned or non-cushioned cylinders available
- Switches are permanently set at factory – no adjustments necessary
- No special filtration required – any cylinder operating fluid acceptable
- Operating point repeatable to .002"
- Quick Response
- Operating temperature range of -4°F to +158°F
- Sensing range .08"
- Short circuit protected
- Immunity to weld field noise
- Typical switching range: 20 to 220 volts AC/DC

Options:

- Low profile, 1 3/8" high above surface (for certain cylinder sizes)
- Mini or micro connections
- Reduced switching voltage available to 10 vdc
- Supplied with or without switches

Design compatible with: Namco and other solid state switches.

How to Order

Series LH Cylinders

Standard Series LH Cylinders can be completely and accurately described by a model number consisting of coded symbols. If your requirements are completely standard, select the symbols from page 23LH that represent your cylinder and place them in the sequence indicated by the example. Use of the cylinder code will eliminate untimely delays in handling your order. Be sure to include with your order all of the information requested in the applications data area.

General Order Data (covered by the cylinder code)

1. Bore & Rod Size or the Cylinder Code: (refer to pages 4LH-11LH)
2. Mounting Style: (refer to 4LH-11LH)
3. Rod End Style: (refer to page 12LH)
4. Cushion Requirements
5. Length of Stroke

Note: Duplicate cylinders can be ordered by giving the serial number from the nameplate of the original cylinder. Factory records supply a quick, positive identification.

Replacement Seals or Cylinder Parts

For replacement seals or cylinder parts, the serial number of your cylinder, the cylinder code and the item number of the

part you require (page 23LH) should appear on your order. To order entire seal kits for your cylinder, simply specify the serial number and the cylinder order number from page 21LH on your request for service parts.

Application Data

1. Port Requirements: refer to page 14LH.
2. Operating Fluid or Medium: Series LH Cylinders are equipped with seals for use with hydraulic oil. If other than a quality grade hydraulic oil will be used, specify the type of fluid in your order.
3. Temperature Range: Series LH Hydraulic Cylinders contain seals of Nitrile (Buna-N) suitable to -30°F to +250°F. Specify your operating temperature if your application does not fall within this temperature range.
4. Operating Pressure: Series LH Cylinders are rated for 1500 PSI to 750. If your requirements are in excess of the rated pressure, describe your application in your order. (Ref. page 17LH, Table 8.)
5. Accessories: Specify any accessories you require, using the part numbers given on page 14LH.
6. Special Requirements: If you require special seals, rod material, stop tube, center support, adjustable stroke or any other special requirements not covered, specify in detail on your order.

Cylinder Order Code – Model Number

ORDER INFORMATION

FEATURE	DESCRIPTION	PAGE NUMBER	CODE NUMBER	EXAMPLE
DOUBLE ROD END		15LH	D	
CYLINDER CODE	REFER TABLE 1	8LH, 10LH, 12LH, 14LH, & 16LH	—	
MOUNTING STYLE	MODEL NUMBER ONLY	7LH, 9LH, 11LH, 13LH, & 15LH	—	
ROD END STYLE	CODE NUMBER	2LH	—	
CUSHIONS	NONE ROD END BLIND END BOTH ENDS	— — — —	1 2 3 4	
CYLINDER MODIFICATIONS	SPECIAL		S	
SEALS	BUNA (-30° TO 250°F) VITON (-15° TO 350°F) SPECIAL		7 8 S	
STROKES	SPECIFY IN INCHES INCLUDING FRACTIONAL REQUIREMENTS		—	

***NOTE:**

Use "S" if any special design features or seals are required, describe in detail on your order.

EXAMPLE:

The code for a hydraulic cylinder 4" bore, 1³/₄" rod, style no. 1 rod end, cushion both ends, standard seals with a 14³/₄" stroke is LH542-31-7 × 14³/₄".

STANDARD PARTS LIST		ITEM NO.	DESCRIPTION	ITEM NO.	DESCRIPTION
		1	PISTON ROD	14	PACKING WASHER
		2	CYLINDER BARREL	15	ROD WIPER
		3	HEAD END CAP	16	O-RING SEAL FOR BALL CHECK RETAINER
		4	CAP END CAP	17	WAVE SPRING
		5	ROD BUSHING	18	CYLINDER BARREL O-RING
		6	RETAINER PLATE	19	WEAR RING
		7	PISTON	20	TIE ROD FLEX LOC NUT
		8	CUSHION PLUNGER	21	TEFLON RING SEAL FOR CUSHION ADJ. NEEDLE
		9	CUSHION ADJ. NEEDLE	22	JAM NUT FOR CUSHION ADJ. NEEDLE
		10	BALL CHECK RETAINER	23	TIE ROD
		11	BALL CHECK	24	SELF-LOCKING CAP SCREW
		12	BLOCK VEE PACKING	25	O-RING FOR FLOATING CUSHION
		13	ROD VEE RING SET		

Dimensional Data

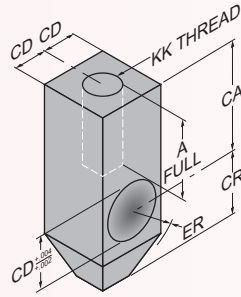
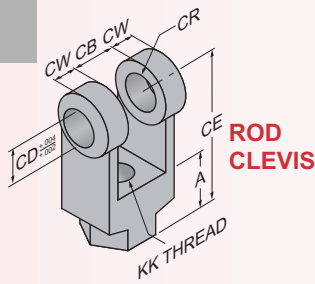

NOTE:

The rod clevis and rod eyes are designed for use with the standard **Milwaukee Style No. 2 Rod End**. When ordering these accessories, be sure to match the thread size of the style No. 2 rod end of the rod size you ordered to the thread size of the accessory you require.

ROD CLEVIS		ROD EYE		MAX. LOAD (TENSION) POUNDS	THD. SIZE KK	A	CA	CB	CD	CE	CR	CW	ER
PART NO.	CODE	PART NO.	CODE										
15-72-1001	C101	15-73-1001	C301	4,380	7/16-20	3/4	1 1/2	3/4	1/2	1 1/2	1/2	1/2	9/16
15-72-1002	C102	15-73-1002	C302	12,372	3/4-16	1 1/8	2 1/16	1 1/4	3/4	2 3/8	3/4	5/8	15/16
15-72-1003	C103	15-73-1003	C303	20,433	1-14	1 5/8	2 13/16	1 1/2	1	3 1/8	1	3/4	1 1/8
15-72-1004	C104	15-73-1004	C304	30,483	1 1/4-12	2	3 7/16	2	1 3/8	4 1/8	1 3/8	1	1 9/16
15-72-1005	C105	15-73-1005	C305	49,479	1 1/2-12	2 1/4	4	2 1/2	1 3/4	4 1/2	1 5/8	1 1/4	1 7/8
15-72-1006	C106	15-73-1006	C306	70,095	1 7/8-12	3	5	2 1/2	2	5 1/2	2	1 1/4	2
15-72-1007	C107	15-73-1007	C307	94,248	2 1/4-12	3 1/2	5 13/16	3	2 1/2	6 1/2	2 1/2	1 1/2	2 1/2
15-72-1008	C108	15-73-1008	C308	121,932	2 1/2-12	3 1/2	6 1/8	3	3	6 3/4	2 3/4	1 1/2	2 3/4
15-72-1009	C109	15-73-1009	C309	187,908	3 1/4-12	4 1/2	7 5/8	4	3 1/2	8 1/2	3 1/2	2	3 1/2
15-72-1010	C110	15-73-1010	C310	268,026	4-12	5 1/2	9 1/8	4 1/2	4	10	4	2 1/4	4

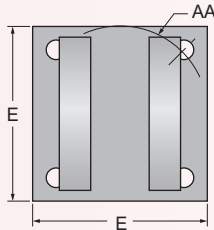
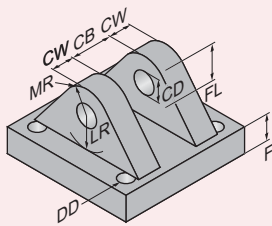

CLEVIS BRACKET

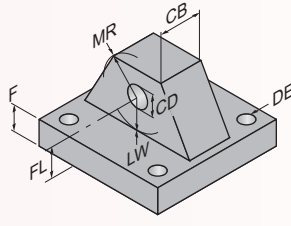

EYE BRACKET

CLEVIS BRACKET		EYE BRACKET		F	FL	MAX. LOAD (TENSION) POUNDS*	MAX. PRESS. (PSI)*	AA	CB	CD	CW	THD SIZE D-D	DE	E	F	FL	LR	LW	MR
PART NO.	CODE	PART NO.	CODE																
15-74-2001	B101	15-75-2001	B401	-	-	7,510	3000	2.3	3/4	1/2	1/2	3/8-24	13/32	2 1/2	3/8	1 1/8	13/16	1 1/16	1/2
15-74-2002	B122	15-75-2002	B422	-	-	20,082	3000	2.9	1 1/4	3/4	5/8	1/2-20	17/32	3	5/8	1 7/8	1 13/16	1 1/4	3/4
15-74-2003	B102	15-75-2003	B402	-	-	20,082	3000	3.6	1 1/4	3/4	5/8	1/2-20	17/32	3 1/2	5/8	1 7/8	1 5/16	1 3/16	3/4
15-74-2004	B103	15-75-2004A	B403A	7/8	2 3/8	27,684	3000	4.6	1 1/2	1	3/4	5/8-18	2 1/32	4 1/2	3/4	2 1/4	1 3/8	1 3/8	1
15-74-2005	B104	15-75-2005	B404	-	-	20,685	3000	5.4	2	1 3/8	1	5/8-18	2 1/32	5	7/8	3	1 7/8	1 7/8	1 3/8
15-74-2006	B105	15-75-2006A	B405A	1 1/8	3 3/8	55,000	3000	7.0	2 1/2	1 3/4	1 1/4	7/8-14	2 9/32	6 1/2	7/8	3 1/8	2	2 1/32	1 5/8
15-74-2007	B106	15-75-2007A	B406A	1 1/2	4	80,000	3000	8.1	2 1/2	2	1 1/4	1-14	1 1/32	7 1/2	1	3 1/2	2 1/16	2 1/16	2
15-74-2008	B107	15-75-2008A	B407A	1 3/4	4 3/4	115,000	3000	9.3	3	2 1/2	1 1/2	1 1/8-12	1 5/32	8 1/2	1	4	2 5/8	2 21/32	2 3/8
15-74-2009	B108	15-75-2009A	B408A	2	5 1/4	125,000	3000	10.6	3	3	1 1/2	1 1/4-12	1 9/32	9 1/2	1	4 1/4	2 7/8	2 7/8	2 3/4

* Eye bracket only ■ Eye brackets with suffix letter "A" reflect revised NFPA standards for F and FL dimensions.

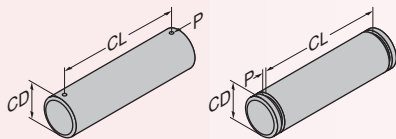

PIVOT PIN

- Pivot pins are furnished with clevis mounted cylinders as standard.
- Pivot pins for 1 1/2"-6" bore are furnished with cotter pins. Pivot pins for 7" thru 12" bore are furnished with snap rings.
- Pivot pins are not furnished as standard and must be ordered separately for use with accessories

PIVOT PIN				
PART NO.	CODE	CD	CL	P
15-76-1001	P101	1/2	1 7/8	9/64
15-76-1002	P102	3/4	2 5/8	9/64
15-76-1003	P103	1	3 1/8	13/64
15-76-1004	P104	1 3/8	4 1/8	13/64
15-76-1005	P105	1 3/4	5 1/8	13/64
15-76-1006	P106	2	5 1/8	17/64
15-76-1007	P107	2 1/2	6 1/8	Groove width .086 to .091
15-76-1008	P108	3	6 3/16	Groove width .103 to .108
15-76-1009	P109	3 1/2	8 1/8	Groove width .120 to .125
15-76-1010	P110	4	9 1/8	Groove width .120 to .125

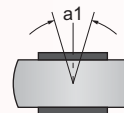
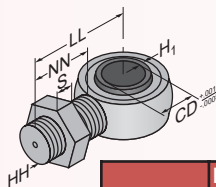

SPHERICAL ROD EYE NOTE:

The spherical rod eye is used with Style 3 and 5 rod ends.

PART NO.	MAX. LOAD (TENSION) POUNDS	SPHERICAL ROD EYE							
		a1	CD	EW	H1	HH	LL	NN	S
HS-301	1,665	12°	1/2	5/8	1 1/16	7/16-20	2 7/16	1 15/32	1/4
HS-302	7,020	13 1/2°	3/4	7/8	2 9/32	3/4-16	2 27/32	1 23/32	7/16
HS-303	19,050	14°	1	1 3/8	1 13/32	1-14	4 3/32	2 3/32	9/16

WARRANTY

Seller warrants the goods sold hereunder to be free from defects in material and workmanship for a period of twelve months after the date of shipment from Seller's plant. If the goods are in accordance with or in reference to an engineering drawing specified by or furnished to the customer, the specifications and information on the drawing shall be applicable in determining such correct use, operation and application.

When claiming a breach of the above warranty, Buyer must notify Seller promptly in writing, whereupon Seller will either examine the goods at their site or issue shipping instructions for return to Seller.

When any goods sold hereunder are proved not as warranted, Seller's sole obligation under this warranty shall be to repair or replace the goods, not including installation or any other charges, at its option, without charge to Buyer.

THIS WARRANTY COMPRISES SELLER'S SOLE AND ENTIRE WARRANTY OBLIGATION AND LIABILITY TO BUYER, ITS CUSTOMERS AND ASSIGNS IN CONNECTION WITH GOODS SOLD HEREUNDER. ALL OTHER WARRANTIES, EXPRESS OR IMPLIED, INCLUDING BUT NOT LIMITED TO WARRANTIES OF MERCHANTABILITY AND FITNESS, ARE EXPRESSLY EXCLUDED.

CONSEQUENTIAL DAMAGES: In no event shall Seller be liable for consequential or special damages arising out of a delay in or failure of delivery, defects in material or workmanship, or arising out of a breach by Seller of any other term or obligation of Seller under this contract.

YOUR MILWAUKEE CYLINDER DISTRIBUTOR

*milwaukee
Cylinder*

5877 S. Pennsylvania Avenue • P.O. Box 100498 • Cudahy, Wisconsin 53110-6108 USA
www.milwaukeeecylinder.com • sales@milwaukeeecylinder.com
Phone: 414-769-9700 • Fax: 414-769-0157