

Unique Features, Quality Products, Value Pricing.

JohnDow Industries is leading the pack with quality, professional products for the automotive service industry.

All five of our product lines complement each other to make JohnDow Industries a leader in our industry.

For more information on our team, visit www.johndow.com.



For more information on JohnDow, call us toll-free at 1.800.433.0708.

JohnDow Industries

151 Snyder Avenue • Barberton, Ohio 44203

Toll-Free Phone: 800.433.0708

Fax: 330.753.6419

web: www.johndow.com

e-mail: customerservice@johndow.com

Member of These Aftermarket Trade Associations:



Distributed By:

Automotive Service Equipment

Our team stands behind yours with performance, reliability, and commitment.



A brand of JohnDow Industries



JD JohnDow
Automotive Service Equipment

Product Quality

JohnDow Industries offers quality products engineered to help our customers achieve greater work efficiencies for a variety of service applications. Our professional tools and equipment are built to endure the rigors of automotive and heavy-duty vehicle service and maintenance.

Professional Product Offering

- Fuel Chief Portable Fuel Storage & Handling
- Crew Chief Used Oil & Fluid Handling
- EuroVent Vehicle Exhaust Extraction
- JohnDow Automotive Service Equipment
- ShopRx Automotive Service Supplies

New Product Innovations

JohnDow Industries continues to support our customers with new products designed for improved benefits and usability in the automotive aftermarket as well as Heavy-Duty, Industrial, and Marine markets.

Delivering Solutions

We believe our advantageous product offering, extensive distribution network, and experienced sales representatives are the best in the country and deliver real solutions to our customers. JohnDow products can be found through virtually every tool and equipment distributor in the country. Please click on the distributors link to locate a JohnDow distributor near you. Our sales agencies are also available to help our customers with any question or request they may have. No request is ever too small.



JohnDow

Automotive Service Equipment

For nearly 30 years the JohnDow name has represented quality built and value priced automotive service equipment.

Whether it's dispensing new oil or grease, crushing oil filters or storing waste oil; customers think of JohnDow. The full-line of equipment is packed with unique features and designed for the true professional.

Our fundamental objective is to supply our customers with professional, quality products that provide solutions to their automotive service needs. We pride ourselves in our ability to service our customers' needs quickly and efficiently.

Used Oil Storage System with Double-Wall Construction

Quality-built Features:

- UL-Listed, double-wall tank in 180- to 500-gallon capacities
 - Double-wall construction provides 110% secondary containment
- UL-Listed, 1" air-operated diaphragm pump with 45 gpm capacity
- Automatic air shut-off prevents overfilling
- Environmental cover.*
- High-gloss enamel paint finish.
- 3/4" x 10' suction hose with quick-connect coupler.
- Manual-operated air inlet shut-off valve.
- Air filter/regulator.
- Air supply connection hose with quick-coupler.*
- 2" drop tube with camlock fitting and dust cover.
- ONE-YEAR LIMITED WARRANTY.
- Fluid level gauge.

*Extra on some competitive models. Standard feature on JohnDow used oil storage systems.

Specifications:

No.	Capacity (Gallons)	Dimensions (L x W x H)	Weight
AGS-180D	180	60" x 28" x 41" (Workbench)	725 lbs.
AGS-245D	245	40" x 37-1/2" x 69" (Vertical)	1100 lbs.
AGS-285D	285	67" x 31" x 44" (Workbench)	1100 lbs.
AGS-500D	500	88-1/2" x 40" x 44" (Workbench)	1300 lbs.



AGS-245D



AGS-285D

Oil Filter Crushers

Air/Hydraulic Oil Filter Crushers

- Heavy-duty aluminum frame cabinet surrounds the high pressure hydraulic hose for added safety and shields components from damage.
- Unitized construction allows for easy maintenance.
- Easy to operate: Load the filter and close the door to activate the crushing cycle.
- Specially designed door channel prevents drips and leakage, keeping oil in the chamber and not on the floor.
- Requires regulator/lubricator (not included).

Shop-Efficient Features:

- Reduce filter size by 75%, and remove over 95% of the residual oil.
- Operates on shop air and can be set up anywhere.
- Compact size takes less than four square feet of floor space.



Heavy-Duty Truck Oil Filter Crusher

No. HDC-150-94

Note: FS-300 floor stand and 16-gallon drum are optional.

Automotive Oil Filter Crusher

No. AFC-100-94



Specifications:

	AFC-100-94	HDC-150-94
Height	28-1/2"	40"
Width	12-3/4"	12-3/4"
Depth	12-3/4"	12-3/4"
Filter height	7-1/2"	13"
Filter diameter	6"	6"
Crushing force	10 tons	15 tons
Pump/type	Air/hydraulic	Air/hydraulic
Weight	111 lbs.	150 lbs.

Floor Stand

No. FS-200

- For AFC-100-04 and HDC-150-94.
- Accommodates a 5-gallon drum.
- Measures 16"w x 18"d x 31"h.
- Weight: 25 lbs.



Floor Stand

No. FS-300

- For AFC-100-04 and HDC-150-94.
- Accommodates a 16-gallon drum.
- Measures 23"w x 23"d x 36"h.
- Weight: 40 lbs.



Floor Stand

No. FS-400

- For AFC-100-94 and HDC-150-94.
- Includes an area to drain used filters before crushing.
- Accommodates a 16-gallon drum.
- Measures 28"w x 23"d x 38"h.
- Weight: 55 lbs.



Wall Bracket

No. WB-200

- Recommended for AFC-100-94.
- Wall anchors not included.
- Weight: 8 lbs.



Regulator/Lubricator

No. FRL-1

- Required for AFC-100-04 and HDC-150-94.
- Weight: 1 lb.



Hose Reels

Professional Series Hose Reels

- Heavy-duty steel construction.
- Durable powder-coat corrosion resistant finish.
- 7" wide "L" shaped base for positive support.
- Four direction non-snap rollers reduce hose wear and abrasion.
- Spring is fully enclosed and lubricated.
- Full-flow swivel prevents leakage.
- Guide arm adjustable up to 9 positions permitting wall, ceiling, or floor mount.

Specifications:

Stock No.	Description	Operating Pressure	Hose I.D.	Hose Length	Weight
Low Pressure					
JD-3850	For air, water and antifreeze	300 psi	3/8"	50'	53 lbs.
JD-1250	For air, water and antifreeze	300 psi	1/2"	50'	59 lbs.
Medium Pressure					
JDM-3850	For motor oil and ATF	2250 psi	3/8"	50'	53 lbs.
JDM-1250	For motor oil and ATF	2000 psi	1/2"	50'	57 lbs.
High Pressure					
JDH-1450	For grease	5000 psi	1/4"	50'	53 lbs.

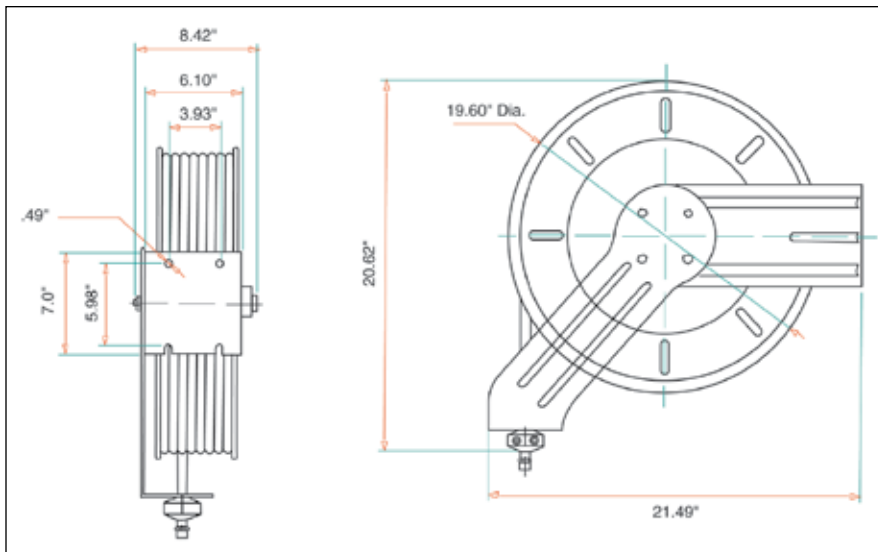

7" wide "L" shaped base for positive support.

General Shop Equipment



T.O.M.C.A.T. Air-Assisted Multiple Camber Adjustment Tool

No. TC-614

- Makes camber adjustment a one-man job.
- Works on many GM and Chrysler vehicles using two-bolt lower strut mounts.
- Inflatable air bladder fits between tire and strut for easy and controlled adjustment of camber settings.
- Camber can be easily set with wheels on the ground.
- Eliminates the need for special camber bolts.

How the T.O.M.C.A.T. Works

1. With strut mount bolts loosened, place the T.O.M.C.A.T. between the tire and strut.
2. Inflate the T.O.M.C.A.T. to push the wheel to a positive camber position.
3. To adjust the camber, slowly release air from the T.O.M.C.A.T. until the wheel retracts to the specified alignment setting.
4. Tighten the bolts and the adjustment is done.

Includes:

- 2' air hose and air bladder.
- Low pressure pop-off valve to prevent overinflating.
- Air control valve for inflating and controlled deflating.
- Weight: 2 lbs.

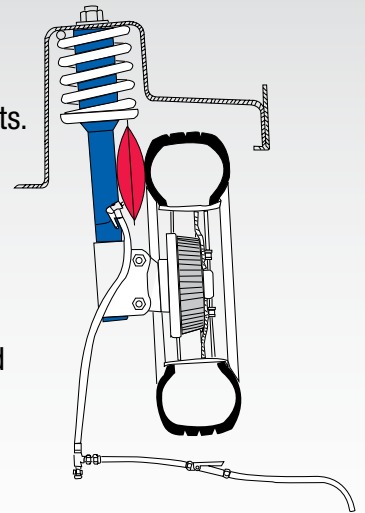

Portable Exhaust Extraction System

No. EV-5100

- The practical and affordable solution for effectively removing toxic exhaust fumes from auto repair facilities, motorcycle shops, small engine repair shops and other work areas where toxic fume removal is needed.
- Positioned next to the vehicle, the high-output suction fan captures fumes and discharges them safely up to 30' away.
- 3/4-hp fan produces 330 cfm air flow.
- Uses standard 110v current.
- Fan is mounted in tough, integrally molded polyethylene "flow thru" case.
- Mobile base makes the EV-5100 easy to position behind the vehicle or move around the shop.
- Height position is controlled by a quick-release, spring-loaded cam lock.
- The discharge hose stores neatly when not in use.



System includes:

Dimensions	24"w x 24"d x 35"h
Motor	3/4 hp 330 cfm
Hose	30'
Electrical outlet	110v
Fuses (Qty=2)	16A
Weight: 86 lbs.	

"Y" Hose adapter

No. EV-ADPT

- For use with dual-exhaust vehicles and motorcycles.
- Works with standard 3" exhaust hoses and "Y" hose adapters.
- Assembles in minutes!
- Does not include hose.
- Weight: 2 lbs.



Lubrication Equipment/Accessories

Pneumatic Grease System for Use with 35-Lb. Container

No. JDL-5

System includes:

JDL-3640	50:1 grease pump
JDH-1014	Outlet hose
JD-3565	Drum cover
JD-3560	Control handle
JD-3570	Follower plate
JD-3840Z	Z-swivel

Weight: 22 lbs.



Pneumatic Grease System for Use with 120-Lb. Container

No. JDL-16 (16C)*

System includes:

JDL-3650	50:1 grease pump
JDH-1014	Outlet hose
JD-3566	Drum cover
JD-3560	Control handle
JD-3571	Follower plate
JD-3840Z	Z-swivel

Weight: 27 lbs. *(16C: 35 lbs.)



*JDL-16C includes caster base.

Pneumatic Grease System for Use with 400-Lb. Container

No. JDL-55

System includes:

JDL-3655	50:1 grease pump
JDH-1014	Outlet hose
JD-3567	Drum cover
JD-3560	Control handle
JD-3572	Follower plate
JD-3840Z	Z-swivel

Weight: 35 lbs.



Rigid Outlet Grease Control Gun

No. JD-3560

- Rigid Outlet.
- 1/4" NPT inlet.
- Heavy-duty continuous flow.
- Weight: 1.5 lbs.

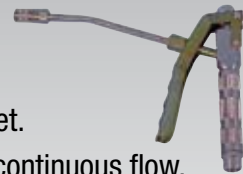

Flexible Outlet Grease Control Gun

No. JD-3560F

- Flexible Outlet.
- 1/4" NPT inlet.
- Heavy-duty continuous flow.
- Weight: 1.5 lbs.



Grease Delivery Hose

No. JDH-1014

- 1/4" I.D. x 8'.
- 1/4" (m) x 1/4" (f).
- 5000 psi rating.
- Weight: 4 lbs.



Z-Swivel

No. JD-3840Z

- 1/4" NPT x 1/4" NPT.
- Permits easy handling of control handle/booster gun when mounted between delivery hose and control valve.
- Weight: 0.5 lbs.



Lubrication Equipment/Accessories

5-Gallon Air-Operated Fluid Dispenser

No. JDI-5DP

- 5-gallon capacity steel tank.
- 2" spout with cap for easy filling.
- Pressure gauge and safety relief valve ensure proper pressurization.
- 7" wheels for easy handling.
- Sight tube shows fluid level.
- Weight: 48 lbs.



15-Gallon Air-Operated Fluid Dispenser

No. JDI-15DP

- Same features as the JDI-5DP, except this unit holds 15 gallons.
- 2-7" wheels and 2-4" heavy-duty casters.
- Weight: 55 lbs.



Pneumatic Oil System for 16-Gallon Open-End Drum with 3:1 Pump

(Shown with optional JDI-16B drum dolly)

No. JDOL-16

System includes:

JD-3615	3:1 oil pump
JDM-1038	10' delivery hose
JD-3930	Oil delivery gun

Weight: 26 lbs.

(Drum not included)



Pneumatic Oil System for 55-Gallon Bung-Type Drum with 3:1 Pump

No. JDOL-55

System includes:

JD-3615	3:1 oil pump
JDM-1038	10' delivery hose
JD-3930	Oil delivery gun

Weight: 22 lbs.

(Drum not included)



Non-Preset Electronic Meter Gun

No. JD-3900

- Lightweight meter gun measures oil, ATF, gear oil and other fluids.
- Non-drip nozzle.
- Measures in quarts & liters.
- Easy-to-read LCD display.
- Includes flex spout with auto tip.
- Weight: 4 lbs.



Preset Electronic Meter Gun

No. JD-K500

- Designed to dispense preset quantity of oil, ATF, gear oil and other compatible fluids.
- Programmable between pints, gallons, quarts, and liters.
- Easy-to-read LCD display.
- Set up to five different preset quantities.
- Discharge spout can be positioned at five different angles.
- Tip rotates 90°.
- Includes rigid spout with auto tip.
- Weight: 5 lbs.

Rigid Oil Gun

No. JD-3930

- Includes handle lock.
- Manual tip.
- Weight: 1.5 lbs.



Flexible Oil Gun

No. JD-3940

- Includes handle lock.
- Automatic tip.
- Weight: 1.5 lbs.



Oil Delivery Hose

No. JDM-1038

- 3/8" I.D. x 10'.
- 1/2" (m) x 1/2" (m).
- 2500 psi rating.
- Weight: 4 lbs.

